

Wheel Loaders

L 550 - L 586

Xpower®

Xpower®

Tipping load:
12,200 – 21,600 kg

Engine:
Stage IV/Tier 4f



LIEBHERR

L 550 XPower®

Tipping load, articulated:

12,200 kg

Bucket capacity:

3.2 m³

Operating weight:

17,700 kg

Engine output (ISO 14396):

140 kW/191 HP

L 556 XPower®

Tipping load, articulated:

13,700 kg

Bucket capacity:

3.6 m³

Operating weight:

18,400 kg

Engine output (ISO 14396):

165 kW/224 HP

L 566 XPower®

Tipping load, articulated:

15,900 kg

Bucket capacity:

4.2 m³

Operating weight:

23,900 kg

Engine output (ISO 14396):

200 kW/272 HP

L 576 XPower®

Tipping load, articulated:

17,600 kg

Bucket capacity:

4.7 m³

Operating weight:

25,700 kg

Engine output (ISO 14396):

215 kW/292 HP

L 580 XPower®

Tipping load, articulated:

19,200 kg

Bucket capacity:

5.2 m³

Operating weight:

27,650 kg

Engine output (ISO 14396):

230 kW/313 HP

L 586 XPower®

Tipping load, articulated:

21,600 kg

Bucket capacity:

6.0 m³

Operating weight:

32,600 kg

Engine output (ISO 14396):

260 kW/354 HP



reddot award 2016
winner

Performance
Power for Increased
Productivity



Economy

Minimum Costs at
High Handling Capacity

Reliability

Robustness and Quality
for Durable Machines

Comfort

Maximum Operator Comfort
for More Productivity

Maintainability

Time and Cost Savings
Through Simple Maintenance



Performance



Power for Increased Productivity

The innovative Liebherr-XPower driveline considerably increases working efficiency. Quick working cycles, high tipping loads and high machine availability lead to increased handling capacity.

Powerful and Efficient Drive Concept

Highest Level of Performance

The Liebherr-XPower driveline brings together the hydrostatic and mechanical drive. The interaction between these two different drives is continuously adjusted automatically to the given application. As a result, XPower® offers the optimal level of efficiency during material loading and transport, as well as providing maximum acceleration and performance along all loading cycles – including long routes. All components are also ideally adapted to each other. XPower® stands for maximum efficiency.

Continuously Variable Transmission

The Liebherr-XPower driveline allows continuous regulation of acceleration in all speed ranges, without noticeable gear shifting or interruption in tractive force. Powerful working and high driving comfort increases productivity.

High Handling Capacity

Unnecessary counterweight can be avoided through the unique component mounting position at the rear of the machine. Ideal weight distribution results in high tipping loads and greater handling capacity per hour of operation.

The Liebherr-XPower driveline accelerates quickly, allowing high travel speeds. Time savings can be made on flat terrain, as well as on inclines. As a result, there are considerable gains in productivity.

Flexibility and Versatility

Lift Arm Variants Optimised for the Application

The standard Z-bar linkage provides a large torque in the lower region of the lift arm. The ideal prerequisite for conventional wheel loader applications – simple, quick filling of the bucket leads to high handling capacity.

An alternative is available in the form of the industrial lift arm for L 550 – L 566 and L 580 wheel loaders at no extra charge. The industrial lift arm boasts a parallel guide arrangement and especially high torque in the upper lifting range. The best solution for industrial use as it allows large attachments to be fitted for transporting heavy loads.

Optimal Bucket Filling

The new robust bucket design from Liebherr allows the bucket to be filled quickly and efficiently. Fully filled attachments increase productivity. The bucket's good penetration and simple filling mechanism result in lower fuel consumption.

Wide Range of Applications

The wide range of attachments means the right tool is always to hand. As a result, a multitude of uses can easily be covered. This increases utilisation of the machine and raises productivity. Liebherr wheel loaders can manoeuvre quickly and efficiently thanks to their compact design – the best choice for high handling capacity.

Liebherr-XPower Driveline

L 550 – L 586

- Future-proof driveline for powerful uses
- Optimum weight distribution due to its unique component mounting position
- Ideal visibility due to its compact design

Conventional

Travel Gear

- Centre of gravity in the middle of the machine
- Additional ballast is needed to increase the tipping load and improve stability
- This leads to bad visibility

An All-Purpose

Loader

The option to choose between industrial lift arm and Z-bar linkage means the right machine is always available for the use specifically required by the customer.

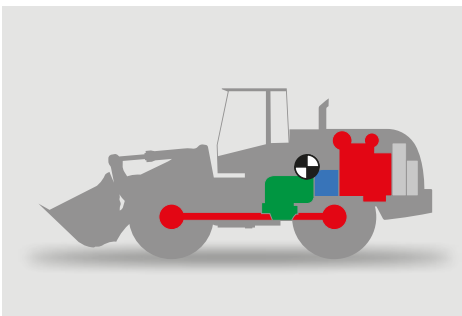
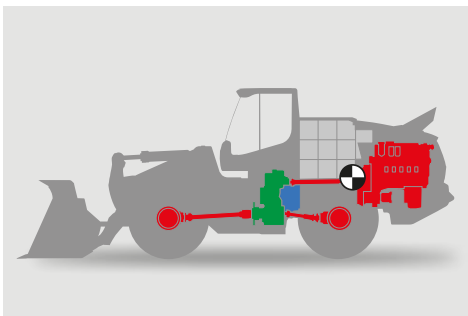

Economy



Minimum Costs at High Handling Capacity

Liebherr wheel loaders make a reliable contribution to commercial success. The fuel-efficient drive concept reduces operating costs and environmental impact at maximum handling capacity.

Low Operating Costs Save Costs and Protect the Environment

LiDAT

Lower Fuel Consumption

The Liebherr-XPower driveline with Liebherr-Power-Efficiency (LPE) achieves a reduction in fuel consumption of up to 30%. At highest efficiency this reduces operating costs and increases profitability.

Hardly Any Brake Wear

The Liebherr-XPower driveline brakes automatically. The service brake only acts as a support and is therefore subject to hardly any wear.

Minimal Tyre Wear

Its continuous traction control, combined with automatic self-locking differential, prevents wheelspin. Productivity is increased and tyre wear reduced by up to 25%.

Innovative Exhaust After-Treatment

The Liebherr-SCR technology is an efficient system for the after-treatment of exhaust gases. Consumables around the engine, such as diesel particle filters, are not required. Regeneration is no longer necessary and maintenance is reduced. Higher productivity provide fuel savings and a reduction in operating costs.

Economical Use of Resources

The lower fuel consumption and efficient exhaust after-treatment cut emissions. This actively saves resources. While actively protecting the environment, Liebherr wheel loaders reduce operating costs.

Efficient Management

LiDAT, Liebherr's own data transmission and positioning system, facilitates efficient management, monitoring and control of the entire fleet park in terms of machinery data recording, data analysis, fleet park management and service. All of the important machinery data can be viewed at any time in a web browser. LiDAT offers you comprehensive work deployment documentation, greater availability thanks to shorter downtimes, faster support from the manufacturer, quicker detection of strain/overload and subsequently a longer service life of the machine as well as greater planning efficiency in your company. This service includes 1 year of use free of charge as standard for the L 550 XPower® – L 586 XPower® wheel loaders.

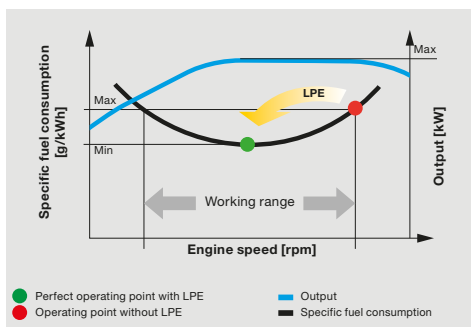

Low Fuel Consumption Thanks to Intelligent Machine Control

- Liebherr-Power-Efficiency (LPE) optimises the interaction between diesel engine, gearbox and working hydraulics for maximum efficiency
- LPE – maximum performance from every drop of fuel

Reduced Brake Wear

- Hardly any brake wear due to hydraulic-mechanical braking action of the driveline

Reduced Tyre Wear

- Continuous traction control prevents the wheels from spinning

Always Be Informed with LiDAT

- Evaluation of machine usage and fuel consumption for economic machine management
- LiDAT comes as standard incl. 1 year free-of-charge use

Reliability



Robustness and Quality for Durable Machines

Liebherr wheel loaders provide maximum performance even under the toughest of operating conditions. Specially-developed components, sophisticated technology and high quality offer a high level of reliability and availability.

OEM Quality Components

Durable and Powerful

Liebherr has many decades of experience in the development, construction and production of components. Ideally adapted to each other, they guarantee a high degree of performance and reliability. Liebherr also develops and produces all steel components. These rugged components ensure the long life of the wheel loaders.

Strenuous endurance tests prove to the strength and quality of the components in use. Even under the toughest of usage conditions, Liebherr wheel loaders satisfy Liebherr's stringent quality standards. This ensures reliable use throughout the entire life time of the machine. Consistently powerful machines increase productivity.



Powerful Liebherr's Own Components

- Ideal interaction of components to each other for maximum performance
- Maximum quality even under the toughest operating conditions
- Rugged, durable machines for reliable operations

High Safe and Versatile Usage

Wear-Free Drive Concept

The components of the Liebherr-XPower driveline are extremely robust and low-wear. The variable distribution of forces between the hydrostatic and mechanical drive also leads to reduced loads on the drive path. XPower® ensures a long life time of the machine and reliability in use.

Continuous Use

Thanks to Liebherr's unique SCR technology, fewer components – such as diesel particle filters or exhaust gas recirculation – are not needed at the engine. This minimises the risk of failure and reduces maintenance expense. This sophisticated technology ensures efficient, continuous work.

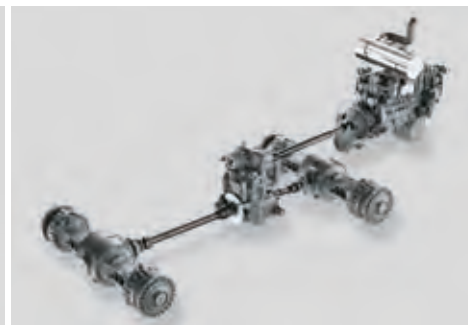

High Machine Availability

- Reduced load on the driveline through the subdivision of forces
- High, safe and versatile usage thanks to robust, low-wear components
- Fewer components around the engine mean reduced risk of failure

Reliable Cooling System

Optimal Cooling Performance

The cooling system is fitted directly behind the operator's cab and is thus able to take in air which is free of dust. In especially dusty applications, optional equipment such as reversible fan drive, fluff trap for the radiator and large-mesh radiator protect the cooling system from contaminants getting in. This guarantees continuous cooling output while simultaneously reducing cleaning expenses. Minimal cleaning expenses mean more efficient, more cost-effective working.

Controlled Cooling

The cooling fan is driven independently from the Liebherr diesel engine and produces exactly the cooling air output which is actually required. Heat sensors ensure reliable control.



Intelligent Cooling System

- Cooling position on the cleanest position of the wheel loader
- High machine availability thanks to lower radiator contamination
- Controlled cooling through thermostatic control for reliable operations

Comfort



Maximum Operator Comfort for More Productivity

The cab design is optimally adapted to the operator's day-to-day requirements. The roomy and ergonomic operator's cab offers perfect conditions for comfortable and productive work.

Clearly Arranged Cab

Productive and Safe Working

The modern, ergonomic cab design allows the operator to work with high concentration without fatigue – this increases safety and productivity. The displays, controls and operator's seat are carefully coordinated to form an ergonomic unit. The optional laterally-sprung operator's seat offers high seating comfort and relaxed working.

Perfect Visibility

The generous glass surfaces of the cab offer exceptional all-round visibility of the attachment and working area. The design of the engine hood which has been optimised for viewing provides ideal viewing towards the rear as well as monitoring behind the machine from the Liebherr display. This ensures maximum safety for people, the machine and the load, while increasing productivity at the same time.

Well-Being Guaranteed

Optimum storage areas and stowage spaces and optional cool-box increase operator well-being. With air conditioning as standard, the improved cooling output ensures a pleasant working atmosphere. This gives the operator maximum comfort and high productivity.

The optional Liebherr key with remote control opens the operator's doors automatically and turns on the lights – for safe and comfortable start-up of the machine.

Simple and Intuitive Operation

Ergonomic Controls

The operating and control instruments are well laid out and user-friendly. All operation-relevant data can be viewed quickly and efficiently. The high operating comfort allows the operator to work particularly efficiently and safely.

Liebherr Control Lever

The Liebherr control lever, which is built into the operator's seat as standard, allows all working and manoeuvring operations to be performed with a high degree of precision and sensitivity. The new electro-hydraulic system allows the operator to programme the lift arm and bucket positions from the cab.

The proportional control of hydraulic attachment is carried out by the Liebherr control lever with mini-joystick. The hydraulic attachment can be controlled with great sensitivity and very ergonomically. The tipping speed for tilting back and dumping can be regulated individually and quickly via the touchscreen display.

Touchscreen Display

The height-adjustable touchscreen display, which comes as standard, allows all operating-relevant machine data to be viewed and configured quickly. Visual and acoustic warning devices ensure high operational reliability.

Exceptional All-Round Visibility

- Unobstructed visibility in all directions through optimal cab and engine hood design
- Generous glass surfaces
- More safety and productivity thanks to exceptional visibility

Liebherr Control Lever with Mini-Joystick (optional)

- Ergonomic and comfortable operation
- Control all driving and operating manoeuvres with a single control lever
- Comfortably programme the hydraulic control from the operator's cab

Intuitive Controls

- Quick recoding of operation-relevant machine data
- Ease of controls increases working efficiency
- Liebherr reverse camera available as standard – built into the touchscreen display



Maintainability



Time and Cost Savings Through Simple Maintenance

The most important points for daily maintenance can be seen at a glance in the access area of Liebherr-XPower wheel loaders. Quick and safe checks save time and money.

Exceptional Service Accessibility

Efficient and Simple Maintenance

Thanks to the unique mounting position of the components, Liebherr wheel loaders offer exceptional accessibility for maintenance. The positioning of the cooling package directly behind the operator's cab contributes to a reduction in maintenance and cleaning expenses by reducing contamination. This saves time and money.

Safe and Free Service Access

All points requiring day-to-day maintenance can be reached comfortably, safely and cleanly. Anti-slip steps and sturdy handrails provide a high degree of safety.

Short Service Times for More Productivity

The engine hood, which opens up electrically towards the rear, ensures safe, free access to the entire engine compartment. The service points are easy to see and reach. All maintenance work can be carried out comfortably and safely from a level base in the engine hood. This ensures time-saving maintenance and increases productivity.

Improved access to the windscreen and cab filter box is provided by the access on the right hand side of the machine. Sturdy hand rails and a fold-out ladder provide a high level of safety during cleaning and maintenance.

Strong Service Partner

Safe Partnership with Strong Service

When buying a Liebherr wheel loader the customer not only looks to a long-lived high-end product but also a reliable longterm partnership. A service network combined with a highly-modern central warehouse is available for optimum service and quick replacement part provision. This guarantees short routes and rapid support in the event of service. Round-the-clock if required.

Competent Liebherr Service Offers Maximum Reliability

Comprehensive know-how ensures a first-class execution of all service and maintenance work. This contributes decisively to the availability and profitability of your machine. Employees at Liebherr service partners are trained on an ongoing basis. They have extensive knowledge of quick and safe service performance. They can turn to the expertise of manufacturing plants at any time.

Low Maintenance

- Less contamination of the radiator thanks to its clever position behind the operator's cab
- Quick and safe control saves time and money

Optimum Service Accessibility

- The entire engine compartment is accessible via just one enclosure
- The most important fill levels can be seen in the loading area
- Short downtimes means more efficiency

Perfect Service for Optimum Machine Availability

- Quick and effective support thanks to an extensive service network
- Replacement parts service with 24-hour delivery
- Quick and reliable service carried out by qualified service specialists



Wheel Loaders L 550 XPower® - L 586 XPower® Overview

Sturdy Attachment

- + Quick working cycles
 - + Durable lift arm
 - + Flexible in use
 - + Efficient and cost-optimised use by specially adapted lift arm variants
-
- ✓ High-quality hydraulic components
 - ✓ Strong steel construction
 - ✓ Wide range of attachments
 - ✓ Industrial lift arm and Z-bar linkage optional

Powerful and Efficient Liebherr-XPower Driveline

- + Fuel savings of up to 30 %
 - + High performance
 - + High safe and versatile usage
 - + Maximum productivity by high tipping load
 - + Tyre wear reduced by up to 25 %
 - + Practically no brake wear
 - + Maximum stability and safety on all terrains
-
- ✓ Drive components optimally suited to each other by LPE
 - ✓ Powerful power split driveline
 - ✓ Rugged and durable driveline
 - ✓ Ideal weight distribution by intelligent arrangement of drive components
 - ✓ Continuous tractive force prevents wheelspin
 - ✓ Self-locking hydraulic-mechanical brake system





Comfortable Operator's Cab

- + Increased performance and productivity
- + Focused operator work is supported
- + Easy and safe operation
- + Excellent all-round visibility

- ✓ New, modern and ergonomic cab design
- ✓ Control of working and travel functions with one control lever
- ✓ Generous glass surfaces

Intelligent Cooling System

- + Constant and reliable cooling
- + Increased service life of components
- + High machine availability through minimal cleaning expenses

- ✓ Controlled cooling
- ✓ Heat sensors ensure reliable control
- ✓ The radiator is installed directly behind the operator's cab – the cleanest position of the wheel loader

Optimum Service Accessibility

- + Time savings in daily maintenance
- + Short service times for more productivity

- ✓ Rapid control of the most important maintenance points in the access area
- ✓ Safe, simple and quick access to all points important for operations

Technical Data

L 550 – L 556

Engine

	L 550	L 556
Diesel engine	D934 A7	D944 A7
Design	Water-cooled in-series engine with charge-air cooling, exhaust after-treatment through Liebherr-SCR technology, closed diesel particle filter system optional	
Cylinder inline	4	4
Fuel injection process	Electronic Common Rail high-pressure injection	
Max. gross output to ISO 3046 and SAE J1995	kW/HP 143/195 at RPM 1,100 – 1,800	168/228 1,100 – 1,800
Max. net output to ISO 9249 and SAE J1349	kW/HP 140/191 at RPM 1,100 – 1,800	165/224 1,100 – 1,800
Rated output to ISO 14396	kW/HP 140/191 at RPM 1,800	165/224 1,800
Max. net torque to ISO 9249 and SAE J1349	Nm 1,215 at RPM 1,100	1,430 1,100
Displacement	litres 7.014	7.964
Bore/Stroke	mm 122/150	130/150
Air cleaner system	Dry type filter with main and safety element, pre-cleaner, service indicator on the Liebherr display	
Electrical system		
Operating voltage	V 24	24
Battery	Ah 2 x 180	2 x 180
Alternator	V/A 28/140	28/140
Starter	V/kW 24/7.8	24/7.8

The exhaust emissions are below the limits in stage IV / Tier 4f.

Driveline

Continuous power split XPower® driveline

Design	Continuous, fully-automatic XPower® driveline. No traction interruptions across the entire speed range. Hydrostatic power split with two axial piston units. Identical driving performance – forwards and in reverse
Filtration	Filter system for driveline, depend on working hydraulics
Control	Driveline is controlled from travel pedal for tractive force and speed setting with integrated inch function. The Liebherr control lever is used to control forward and reverse travel
Travel speed range	0 – 40 km/h forward and reverse, fully-automatic Speed restriction available upon request. Speeds quoted apply with the tyres indicated as standard on loader model.

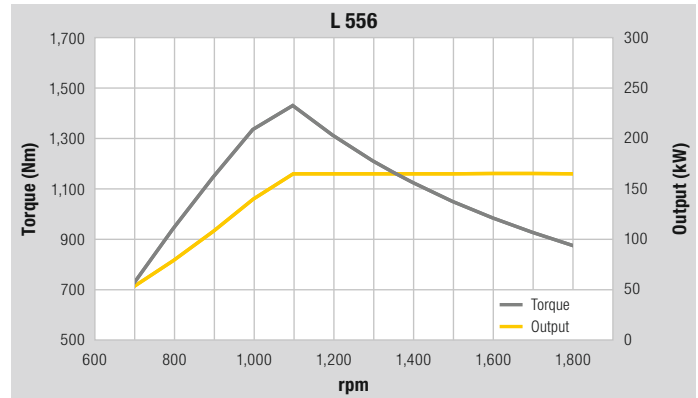
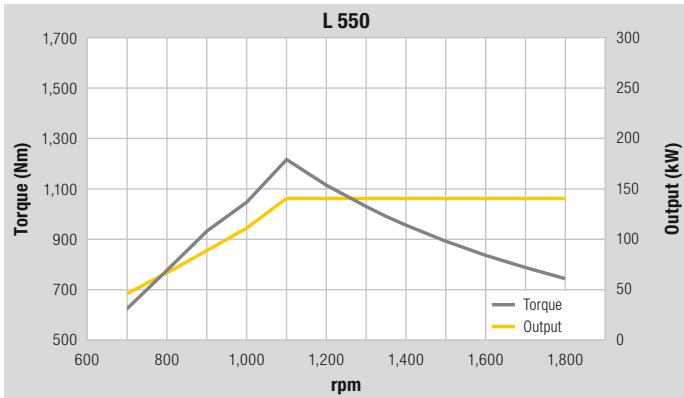

Axles

	L 550	L 556
Four-wheel drive		
Front axle	Fixed	
Rear axle	Centre pivot, with 13° oscillating angle to each side	
Height of obstacles which can be driven over	mm 460	442
	with all four wheels remaining in contact with the ground	
Differentials	Automatic limited-slip differentials	
Reduction gear	Planetary final drive in wheel hubs	
Track width	2,003 mm with all types of tyres	

Brakes

Wear-free service brake	Self-locking of the XPower® driveline (acting on all four wheels) and additional pump-accumulator brake system with wet multi-disc brakes (two separate brake circuits)
Parking brake	Electro-hydraulically actuated spring-loaded disc brake system on the transmission

The braking system meets the requirements of the EC guidelines 71 / 320.

Steering

Design	"Load-sensing" swash plate type variable flow pump with pressure cut-off and flow control. Central pivot with two double-acting, damped steering cylinders
Angle of articulation	40° to each side
Emergency steering	Electro-hydraulic emergency steering system

Attachment Hydraulics

	L 550	L 556
Design	"Load-sensing" swash plate type variable flow pump with output and flow control, and pressure cut-off in the control block	
Cooling	Hydraulic oil cooling using thermostatically controlled fan and oil cooler	
Filtration	Return line filter in the hydraulic reservoir	
Control	Liebherr control lever, electro-hydraulically operated	
Lift circuit	Lifting, neutral, lowering Automatic hoisting and lowering by Liebherr control lever Float position controlled by Liebherr control lever	
Tilt circuit	Tilt back, neutral, dump Automatic bucket return for tilting back and dumping controlled by Liebherr control lever	
Max. flow	l/min. 234	234
Max. pressure		
Z-bar linkage	bar 330	360
Industrial lift arm	bar 350	380

Attachment

	L 550	L 556		
Geometry variants				
Optional	Powerful Z-bar linkage with tilt cylinder and cast steel cross-tube Industrial lift arm with tilt cylinder, hydraulic quick hitch as standard			
Bearings	Sealed			
Cycle time at nominal load	ZK	IND	ZK	IND
Lifting	s 5.5	5.5	5.5	5.5
Dumping	s 2.3	3.5	2.3	3.5
Lowering (empty)	s 2.7	2.7	2.7	2.7

Operator's Cab

Design	Hydraulically mounted, noise-proof cab ROPS roll over protection per EN ISO 3471 / EN 474-1 FOPS falling objects protection per EN ISO 3449 / EN 474-1, Cat. II Operator's door with sliding side window, sliding side window on right, front windscreen made of compound safety glass, side panels with single-pane safety glass ESG, heated rear window ESG, all windows are tinted. 3 way continuous adjustable steering column
Liebherr operator's seat	6 way adjustable, vibration-damped operator's seat "Comfort" with seat, depth and incline adjustment as standard (air-cushioned with seat heating adjustable to operator's weight), Liebherr control lever mounted into the operator's seat as standard
Cab heating and ventilation	4-zone air conditioning with new improved cooling output as standard, all filters are easy to access and replaceable

Sound Level

	L 550	L 556
Sound pressure level to ISO 6396		
L _{PA} (inside cab)	dB(A) 68	68
Sound power level to 2000 /14/EC		
L _{WA} (surround noise)	dB(A) 104	104

Capacities

	L 550	L 556
Fuel tank	l 280	280
Engine oil (inclusive filter change)	l 26	26
DEF tank	l 67.5	67.5
Pump distribution gearbox	l 1.2	1.2
XPower® gearbox	l 53	53
Coolant	l 67	67
Front axle	l 35	42
Rear axle	l 35	35
Hydraulic tank	l 105	105
Hydraulic system, total	l 175	175
Air conditioning system R134a	g 1,250	1,250

Dimensions

Z-bar Linkage

L 550 – L 556

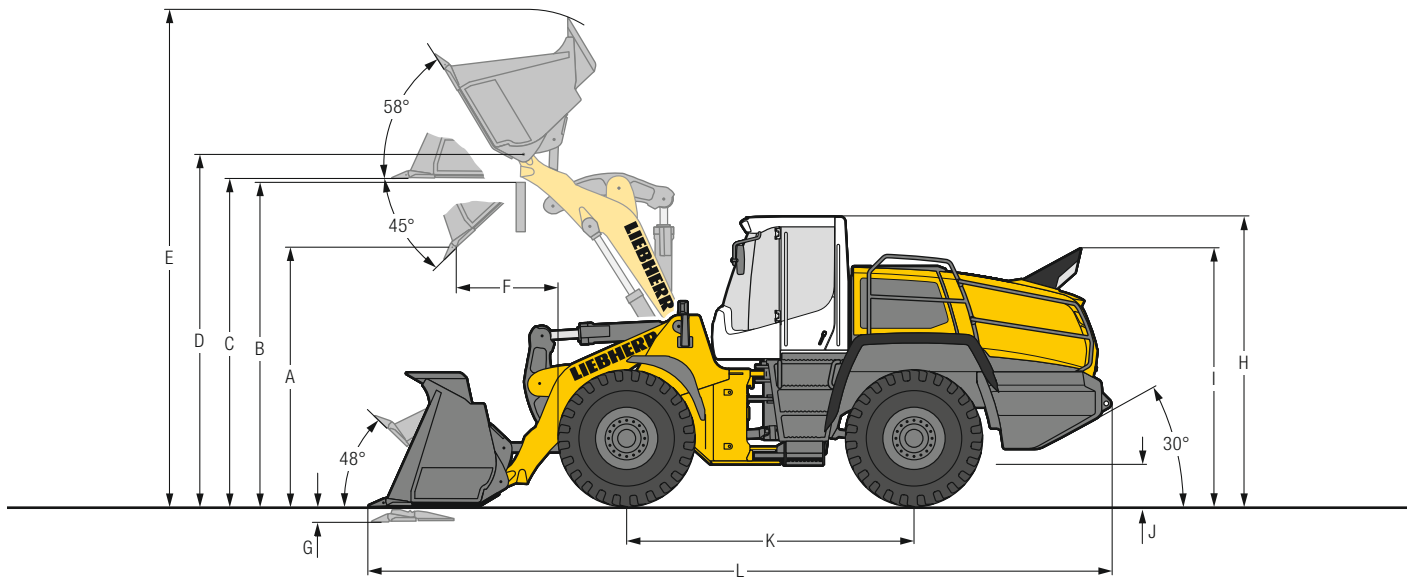

Excavation Bucket



	L 550		L 556	
	ZK	ZK	ZK	ZK
Geometry				
Cutting tools	T	T	T	T
Lift arm length	mm	2,600	2,600	2,600
Bucket capacity according to ISO 7546**	m ³	3.2	3.6	4.0
Specific material density	t/m ³	1.85	1.65	1.65
Bucket width	mm	2,700	2,700	2,700
A Dumping height at max. lift height and 45° discharge	mm	2,880	2,810	2,740
B Dump-over height	mm	3,500	3,500	3,500
C Max. height of bucket bottom	mm	3,645	3,645	3,645
D Max. height of bucket pivot point	mm	3,915	3,915	3,915
E Max. operating height	mm	5,585	5,695	5,775
F Reach at max. lift height and 45° discharge	mm	1,095	1,170	1,250
G Digging depth	mm	85	85	85
H Height above operator's cab	mm	3,370	3,370	3,370
I Height above exhaust	mm	3,020	3,020	3,020
J Ground clearance	mm	490	490	490
K Wheelbase	mm	3,395	3,395	3,395
L Overall length	mm	8,380	8,480	8,580
Turning circle radius over outside bucket edge	mm	6,585	6,610	6,635
Breakout force (SAE)	kN	140	130	150
Tipping load, straight*	kg	14,000	13,800	15,750
Tipping load, fully articulated*	kg	12,200	12,000	13,500
Operating weight*	kg	17,700	17,800	18,400
Tyre size		23.5R25 L3		23.5R25 L3

* The figures shown include the above tyres, all lubricants, a full fuel tank, the ROPS/FOPS cab and the operator.

Different tyres and optional equipment will change the operating weight and tipping load. (Tipping load, fully articulated according to ISO 14397-1)

** Actual bucket capacity may be approx. 10% larger than the calculation according to ISO 7546 standard.

The degree to which the bucket can be filled depends on the material – see page 24.

ZK = Z-bar linkage

T = Welded-on tooth holder with add-on teeth

Dimensions

Industrial Lift Arm

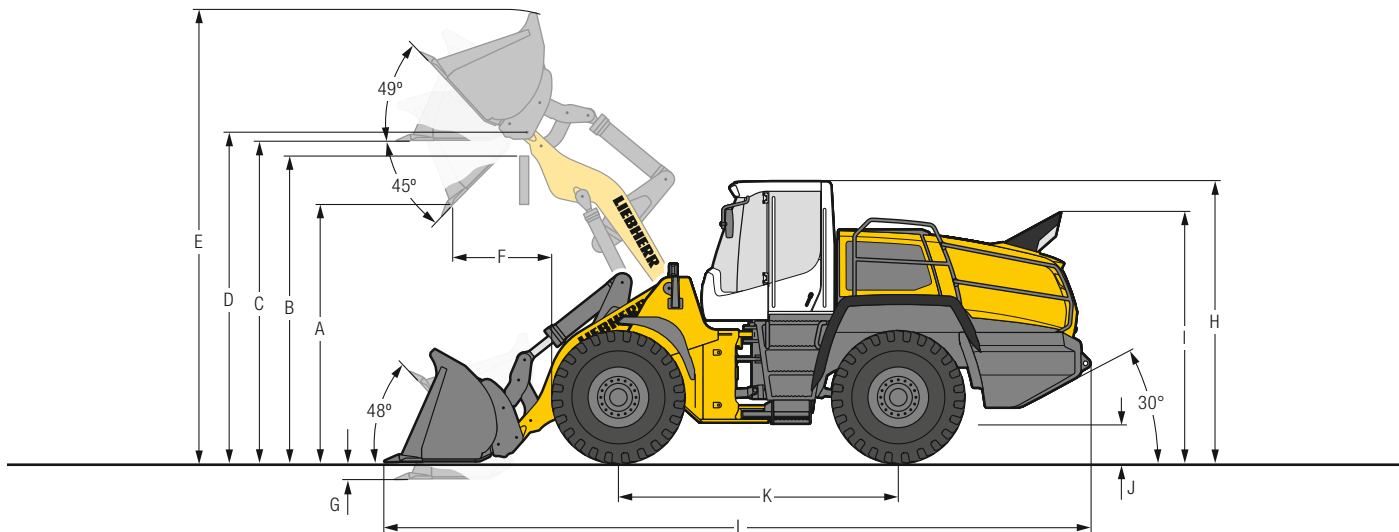

Excavation Bucket



		L 550			L 556		
		STD	HL	HL	STD	HL	HL
Geometry		IND-QH	IND-QH	IND-QH	IND-QH	IND-QH	IND-QH
Cutting tools		T	T	T	T	T	T
Lift arm length	mm	2,600	3,000	3,000	2,600	3,000	3,000
Bucket capacity according to ISO 7546**	m ³	3.0	2.6	2.8	3.3	2.8	3.0
Specific material density	t/m ³	1.8	1.8	1.6	1.8	1.8	1.6
Bucket width	mm	2,700	2,700	2,700	2,700	2,700	2,700
A Dumping height at max. lift height and 45° discharge	mm	2,880	3,550	3,520	2,850	3,520	3,460
B Dump-over height	mm	3,500	4,100	4,100	3,500	4,100	4,100
C Max. height of bucket bottom	mm	3,795	4,360	4,360	3,795	4,360	4,360
D Max. height of bucket pivot point	mm	4,075	4,640	4,640	4,075	4,640	4,640
E Max. operating height	mm	5,580	6,090	6,120	5,620	6,120	6,160
F Reach at max. lift height and 45° discharge	mm	1,135	940	960	1,174	960	1,015
G Digging depth	mm	80	80	80	80	80	80
H Height above operator's cab	mm	3,370	3,370	3,370	3,370	3,370	3,370
I Height above exhaust	mm	3,020	3,020	3,020	3,020	3,020	3,020
J Ground clearance	mm	490	490	490	490	490	490
K Wheelbase	mm	3,395	3,395	3,395	3,395	3,395	3,395
L Overall length	mm	8,550	8,940	9,000	8,605	9,000	9,080
Turning circle radius over outside bucket edge	mm	6,630	6,830	6,850	6,650	6,850	6,885
Breakout force (SAE)	kN	125	136	134	130	134	125
Tipping load, straight*	kg	12,800	10,700	10,600	14,400	12,000	11,800
Tipping load, fully articulated*	kg	11,100	9,200	9,100	12,400	10,300	10,100
Operating weight*	kg	18,700	18,900	18,950	19,500	19,700	19,750
Tyre size		23.5R25 L3			23.5R25 L3		

* The figures shown include the above tyres, all lubricants, a full fuel tank, the ROPS/FOPS cab and the operator.

Different tyres and optional equipment will change the operating weight and tipping load. (Tipping load, fully articulated according to ISO 14397-1)

** Actual bucket capacity may be approx. 10% larger than the calculation according to ISO 7546 standard.

The degree to which the bucket can be filled depends on the material – see page 24.

STD = Standard lift arm length

HL = High Lift

IND-QH = Industrial lift arm with parallel guidance incl. quick hitch

T = Welded-on tooth holder with add-on teeth

Attachment

Light Material Bucket

L 550 – L 556

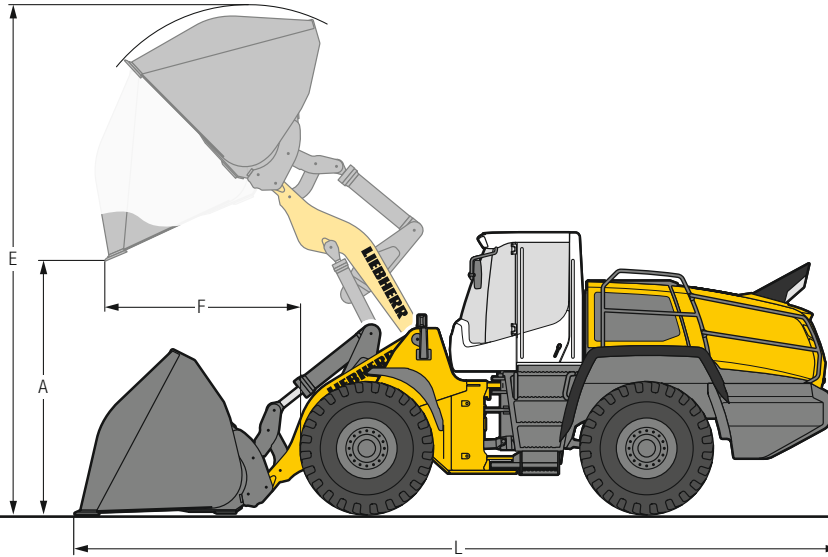

Heavy Material Density



	L 550		L 556	
	STD	HL	STD	HL
Geometry	IND-QH	IND-QH	IND-QH	IND-QH
Cutting tools	BOCE	BOCE	BOCE	BOCE
Bucket capacity	m ³ 5.0	4.5	5.5	5.0
Specific material density	t/m ³ 1.0	1.0	1.0	0.95
Bucket width	mm 2,950	2,950	2,950	2,950
A Dumping height at max. lift height	mm 2,550	3,220	2,450	3,130
E Max. operating height	mm 5,900	6,320	6,060	6,480
F Reach at maximum lift height	mm 1,450	1,250	1,550	1,330
L Overall length	mm 8,770	9,170	8,900	9,280
Tipping load, straight*	kg 11,900	9,800	13,200	11,100
Tipping load, fully articulated*	kg 10,200	8,300	11,300	9,400
Operating weight*	kg 19,200	19,400	20,100	20,300
Tyre size	23.5R25 L3		23.5R25 L3	

Light Material Density



	L 550		L 556	
	STD	HL	STD	HL
Geometry	IND-QH	IND-QH	IND-QH	IND-QH
Cutting tools	BOCE	BOCE	BOCE	BOCE
Bucket capacity	m ³ 9.0	8.0	10.0	9.0
Specific material density	t/m ³ 0.5	0.5	0.5	0.5
Bucket width	mm 3,400	3,400	3,400	3,400
A Dumping height at max. lift height	mm 2,340	2,920	2,265	2,840
E Max. operating height	mm 6,110	6,470	6,250	6,600
F Reach at maximum lift height	mm 1,705	1,520	1,780	1,600
L Overall length	mm 9,140	9,570	9,250	9,690
Tipping load, straight*	kg 11,500	9,400	13,100	10,700
Tipping load, fully articulated*	kg 9,800	7,900	11,100	8,900
Operating weight*	kg 19,700	19,900	20,500	20,800
Tyre size	23.5R25 L3		23.5R25 L3	

* The figures shown include the above tyres, all lubricants, a full fuel tank, the ROPS/FOPS cab and the operator.

Different tyres and optional equipment will change the operating weight and tipping load. (Tipping load, fully articulated according to ISO 14397-1)

STD = Standard lift arm length

HL = High Lift

IND-QH = Industrial lift arm with parallel guidance incl. quick hitch

BOCE = Bolt-on cutting edge

Attachment

High-Dump Bucket

L 550 – L 556

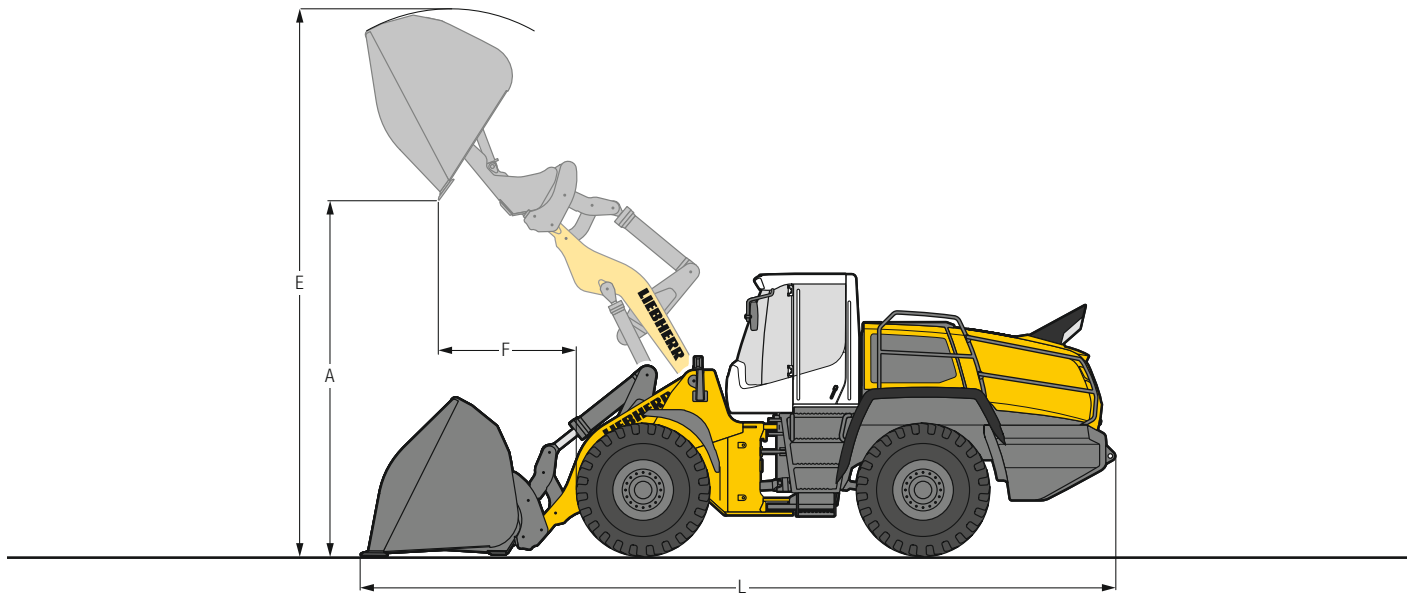

Heavy Material Density



	L 550		L 556	
	STD	HL	STD	HL
Geometry	IND-QH	IND-QH	IND-QH	IND-QH
Cutting tools	BOCE	BOCE	BOCE	BOCE
Bucket capacity	m ³ 4.5	4.0	5.0	4.5
Specific material density	t/m ³ 1.0	1.0	1.0	1.0
Bucket width	mm 2,700	2,700	2,700	2,700
A Dumping height at max. lift height	mm 4,550	5,040	4,590	5,160
E Max. operating height	mm 6,680	7,120	6,850	7,300
F Reach at maximum lift height	mm 1,790	1,560	1,820	1,650
L Overall length	mm 9,000	9,410	9,120	9,550
Tipping load, straight*	kg 11,400	9,200	12,900	10,500
Tipping load, fully articulated*	kg 9,700	7,700	10,900	8,900
Operating weight*	kg 19,700	19,900	20,600	20,800
Tyre size	23.5R25 L3		23.5R25 L3	

Light Material Density



	L 550		L 556	
	STD	HL	STD	HL
Geometry	IND-QH	IND-QH	IND-QH	IND-QH
Cutting tools	BOCE	BOCE	BOCE	BOCE
Bucket capacity	m ³ 8.5	7.5	9.5	8.5
Specific material density	t/m ³ 0.5	0.5	0.5	0.5
Bucket width	mm 3,400	3,400	3,400	3,400
A Dumping height at max. lift height	mm 4,450	4,800	4,610	4,950
E Max. operating height	mm 6,900	7,200	7,150	7,500
F Reach at maximum lift height	mm 1,800	1,580	1,860	1,650
L Overall length	mm 9,200	9,590	9,290	9,750
Tipping load, straight*	kg 10,900	8,700	12,500	10,100
Tipping load, fully articulated*	kg 9,300	7,300	10,500	8,400
Operating weight*	kg 20,300	20,400	21,200	21,300
Tyre size	23.5R25 L3		23.5R25 L3	

* The figures shown include the above tyres, all lubricants, a full fuel tank, the ROPS/FOPS cab and the operator.

Different tyres and optional equipment will change the operating weight and tipping load. (Tipping load, fully articulated according to ISO 14397-1)

STD = Standard lift arm length

HL = High Lift

IND-QH = Industrial lift arm with parallel guidance incl. quick hitch

BOCE = Bolt-on cutting edge

Attachment

Fork Carrier and Fork

L 550 – L 556

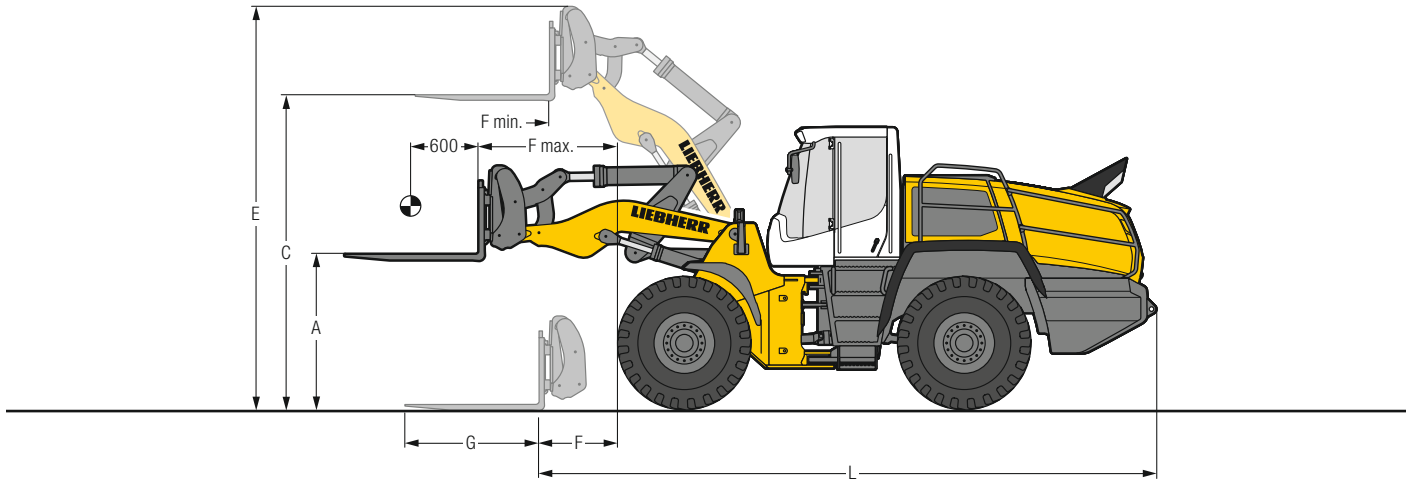

FEM IV Fork Carrier and Fork



		L 550	L 556
Geometry		IND-QH	IND-QH
A	Lifting height at max. reach	mm	1,840
C	Max. lifting height	mm	3,835
E	Max. operating height	mm	4,825
F	Reach at loading position	mm	985
F max.	Max. reach	mm	1,680
F min.	Reach at max. lifting height	mm	750
G	Fork length	mm	1,500
L	Length – basic machine	mm	7,380
	Tipping load, straight*	kg	9,500
	Tipping load, fully articulated*	kg	8,300
	Recommended payload for uneven ground = 60% of tipping load, articulated ¹⁾	kg	4,980
	Recommended payload for smooth surfaces = 80% of tipping load, articulated ¹⁾	kg	7,360
	Operating weight*	kg	17,800
	Tyre size	23.5R25 L3	23.5R25 L3

* The figures shown include the above tyres, all lubricants, a full fuel tank, the ROPS/FOPS cab and the operator.

Different tyres and optional equipment will change the operating weight and tipping load. (Tipping load, fully articulated according to ISO 14397-1)

¹⁾ According to EN 474-3

IND-QH = Industrial lift arm with parallel guidance incl. quick hitch

Attachment

Log Grapple

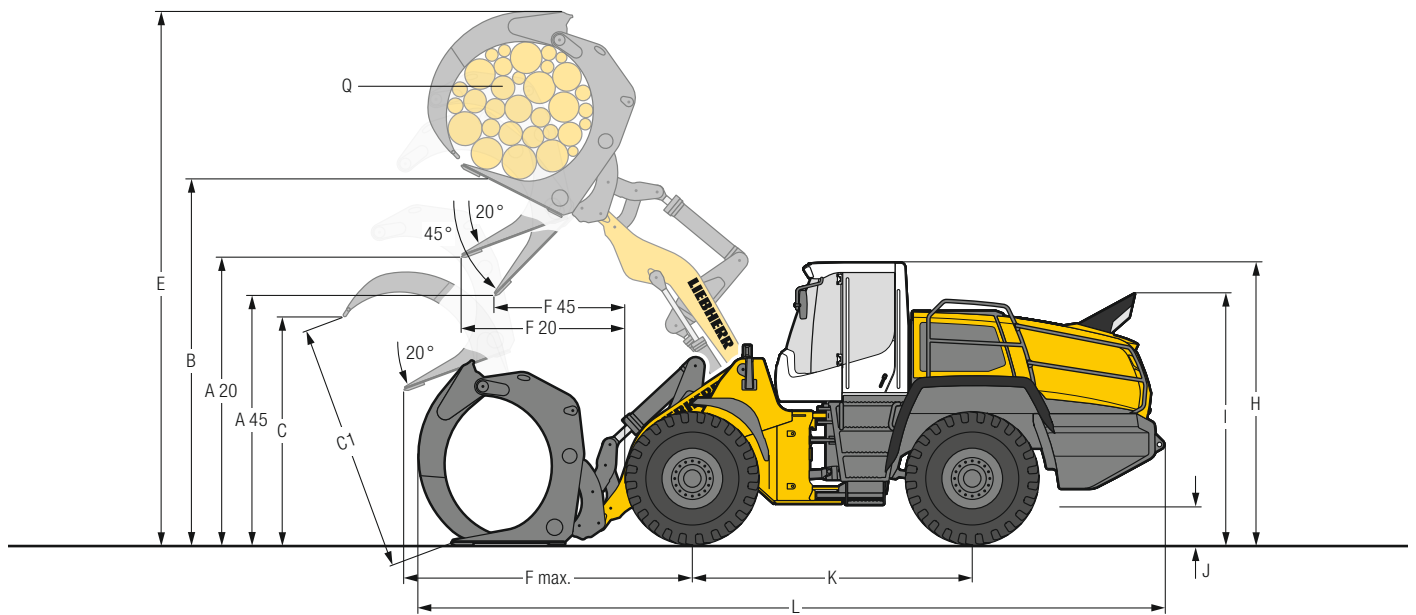

L 550 – L 556

Log Grapple



		L 550	L 556
	Geometry	IND-QH	IND-QH
A20	Discharge height at 20°	3,590	3,570
A45	Discharge height at 45°	3,020	2,950
B	Manipulation height	4,530	4,530
C	Max. grapple opening in loading position	2,395	2,740
C1	Max. grapple opening	2,590	2,990
E	Max. height	6,320	6,480
F20	Reach at max. lifting height at 20° discharge	1,740	1,890
F45	Reach at max. lifting height at 45° discharge	1,410	1,530
F max.	Max. reach	2,670	2,820
H	Height above operator's cab	3,395	3,395
I	Height above exhaust	3,045	3,045
J	Ground clearance	510	510
K	Wheelbase	3,395	3,395
L	Overall length	8,720	8,870
	Width over tyres	2,650	2,650
Q	Grapple diameter	1.8	2.4
	Grapple width	1,600	1,600
	Payload*	6,300	6,400
	Operating weight*	19,700	20,500
	Tyre size	23.5R25 L4	23.5R25 L4

* The figures shown include the above tyres, all lubricants, a full fuel tank, the ROPS/FOPS cab and the operator. Different tyres and optional equipment will change the operating weight and payload.

IND-QH = Industrial lift arm with parallel guidance incl. quick hitch

Bucket Selection

L 550 – L 556

L 550

Lift arm	Bucket	Material density (t/m³)									
		0.4	0.6	0.8	1.0	1.2	1.4	1.6	1.8	2.0	
ZK	GPB ₁	3.2 m³							3.5		3.2
		3.6 m³						4.0		3.6	
IND-QH	GPB ₁	3.0 m³							3.3		3.0
		5.0 m³			5.5					5.0	
	LMB	9.0 m³	9.0								
		4.5 m³			5.0					4.5	
	HDB	8.5 m³	8.5								
		2.6 m³							2.9		2.6
IND-QH-HL	GPB ₁	2.8 m³						3.1		2.8	
		4.5 m³			5.0					4.5	
	LMB	8.0 m³	8.0								
		4.0 m³			4.4					4.0	
	HDB	7.5 m³	7.5								

L 556

Lift arm	Bucket	Material density (t/m³)										
		0.4	0.6	0.8	1.0	1.2	1.4	1.6	1.8	2.0		
ZK	GPB ₁	3.6 m³								4.0		3.6
		4.0 m³							4.4		4.0	
IND-QH	GPB ₁	3.3 m³								3.6		3.3
		5.5 m³			6.1						5.5	
	LMB	10.0 m³	10.0									
		5.0 m³			5.5					5.0		
	HDB	9.5 m³	9.5									
		2.8 m³								3.1		2.8
IND-QH-HL	GPB ₁	3.0 m³							3.3		3.0	
		5.0 m³			5.5						5.0	
	LMB	9.0 m³	9.0									
		4.5 m³			5.0					4.5		
	HDB	8.5 m³	8.5									

Bucket Filling Factor

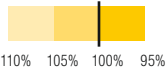

Lift Arm

ZK	Z-bar linkage, standard lift arm length
IND-QH	Industrial lift arm with quick hitch, standard lift arm length
IND-QH-HL	Industrial lift arm with quick hitch, High Lift

Bucket

GPB₁	General purpose bucket (Excavation bucket)
LMB	Light material bucket
HDB	High-dump bucket

Bulk Material Densities and Bucket Filling Factors

		t/m³	%			t/m³	%			t/m³	%
Gravel	moist	1.9	105	Earth	dry	1.3	115	Glass waste	broken	1.4	100
	dry	1.6	105		wet excavated	1.6	110		solid	1.0	100
	crushed stone	1.5	100	Topsoil		1.1	110	Compost	dry	0.8	105
Sand	dry	1.5	105	Basalt		1.95	100	wet	1.0	110	
	wet	1.9	110	Granite		1.8	95	Wood chips/Saw dust		0.5	110
Gravel and Sand	dry	1.7	105	Sandstone		1.6	100	Paper	shredded/loose	0.6	110
Sand/Clay	wet	2.0	100	Slate		1.75	100	recovered paper/cardboard	1.0	110	
Clay	natural	1.6	110	Bauxite		1.4	100	Coal	heavy material density	1.2	110
Clay/Gravel	dry	1.4	110	Limestone		1.6	100	light material density	0.9	110	
	wet	1.6	100	Gypsum	broken	1.8	100	Waste	domestic waste	0.5	100
				Coke		0.5	110	bulky waste	1.0	100	
				Slag	broken	1.8	100				



Tyre Types

	Size and tread code		Change of operating weight kg	Width over tyres mm	Change in vertical dimensions * mm	Use
L 550 XPower® / L 556 XPower®						
Bridgestone	23.5R25 VJT	L3	138	2,670	6	Bulk material (firm ground conditions)
Bridgestone	23.5R25 VLTS	L4	360	2,670	39	Gravel, Industry (firm ground conditions)
Bridgestone	23.5R25 VSDL	L5	898	2,660	65	Stone, Scrap, Recycling (firm ground conditions)
Bridgestone	23.5R25 VSDT	L5	851	2,670	55	Stone, Scrap, Recycling (firm ground conditions)
Bridgestone	650/65R25 VTS	L3	4	2,700	- 30	Gravel (all ground conditions)
Bridgestone	750/65R25 VTS	L3	728	2,880	11	Gravel, Industry, Wood (all ground conditions)
Goodyear	23.5R25 RT-3B	L3	188	2,670	20	Gravel (all ground conditions)
Goodyear	23.5R25 TL-3A+	L3	284	2,670	36	Sand, Gravel, Earthworks, Clay (all ground conditions)
Goodyear	23.5R25 GP-4D	L4	328	2,690	25	Gravel, Industry, Wood (firm ground conditions)
Goodyear	23.5R25 RL-4K	L4	500	2,680	39	Gravel, Industry, Stone (firm ground conditions)
Goodyear	23.5R25 RL-5K	L5	936	2,680	57	Stone, Scrap, Recycling (firm ground conditions)
Goodyear	23.5R25 RL-5S	L5	968	2,680	57	Scrap, Recycling, Slag (firm ground conditions)
Goodyear	23.5R25 RT-5D	L5	820	2,660	55	Stone, Mining spoil (firm ground conditions)
Goodyear	750/65R25 TL-3A+	L3	680	2,910	24	Sand, Gravel, Industry, Wood (all ground conditions)
Michelin	23.5R25 XHA2	L3	0	2,650	0	Sand, Gravel (all ground conditions)
Michelin	23.5R25 XTLA	L2	- 12	2,650	- 4	Gravel, Earthworks, Clay (all ground conditions)
Michelin	23.5R25 XMINE	L5	760	2,690	61	Stone, Scrap, Recycling (firm ground conditions)
Michelin	23.5R25 XLD D2A	L5	612	2,670	26	Stone, Mining spoil (firm ground conditions)
Michelin	650/65R25 XLD65	L3	- 112	2,690	- 53	Gravel, Industry, Wood (all ground conditions)
Michelin	750/65R25 XLD65	L3	524	2,870	- 7	Gravel, Industry, Wood (all ground conditions)

* The stated values are theoretical and may deviate in practice.

Before operating the vehicle with tyre foam filling or tyre protection chains, please discuss this with the Liebherr-Werk Bischofshofen GmbH.

Technical Data

Engine

	L 566	L 576	L 580	L 586
Diesel engine	D936 A7	D936 A7	D936 A7	D936 A7
Design	Water-cooled in-series engine with charge-air cooling, exhaust after-treatment through Liebherr-SCR technology, closed diesel particle filter system optional			
Cylinder inline	6	6	6	6
Fuel injection process	Electronic Common Rail high-pressure injection			
Max. gross output to ISO 3046 and SAE J1995	kW/HP 203/276	218/296	233/317	263/358
at RPM	1,000 – 1,800	1,100 – 1,800	1,200 – 1,800	1,300 – 1,800
Max. net output to ISO 9249 and SAE J1349	kW/HP 200/272	215/292	230/313	260/354
at RPM	1,000 – 1,800	1,100 – 1,800	1,200 – 1,800	1,300 – 1,800
Rated output to ISO 14396	kW/HP 200/272	215/292	230/313	260/354
at RPM	1,800	1,800	1,800	1,800
Max. net torque to ISO 9249 and SAE J1349	Nm 1,910	1,965	1,965	1,965
at RPM	1,000	1,000	1,000	1,000
Displacement	litres 10.52	10.52	10.52	10.52
Bore/Stroke	mm 122/150	122/150	122/150	122/150
Air cleaner system	Dry type filter with main and safety element, pre-cleaner, service indicator on the Liebherr display			
Electrical system				
Operating voltage	V 24	24	24	24
Battery	Ah 2 x 180	2 x 180	2 x 180	2 x 180
Alternator	V/A 28/140	28/140	28/140	28/140
Starter	V/kW 24/7.8	24/7.8	24/7.8	24/7.8

The exhaust emissions are below the limits in stage IV/Tier 4f.

Driveline

Continuous power split XPower® driveline

Design	Continuous, fully-automatic XPower® driveline. No traction interruptions across the entire speed range. Hydrostatic power split with two axial piston units. Identical driving performance – forwards and in reverse
Filtration	Filter system for driveline, depend on working hydraulics
Control	Driveline is controlled from travel pedal for tractive force and speed setting with integrated inch function. The Liebherr control lever is used to control forward and reverse travel
Travel speed range	L 566 – L 580: 0 – 40 km/h forward and reverse, fully-automatic L 586: 0 – 33 km/h forward and reverse, fully-automatic Speed restriction available upon request. Speeds quoted apply with the tyres indicated as standard on loader model.

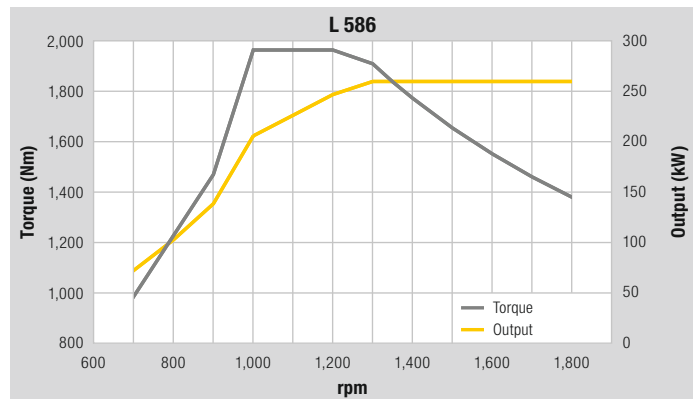
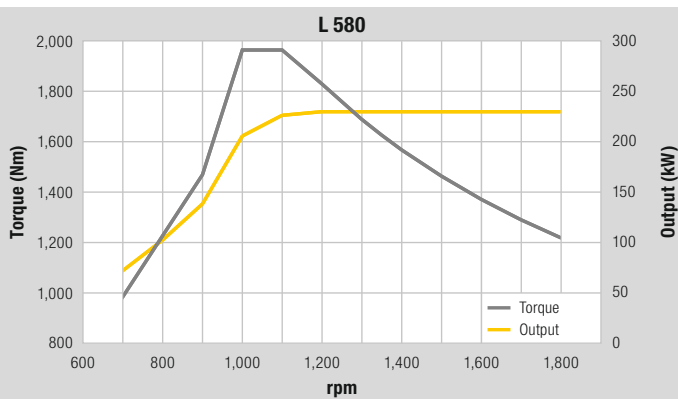
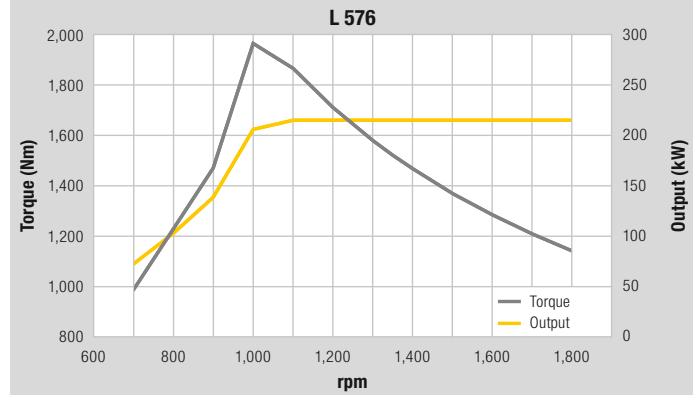
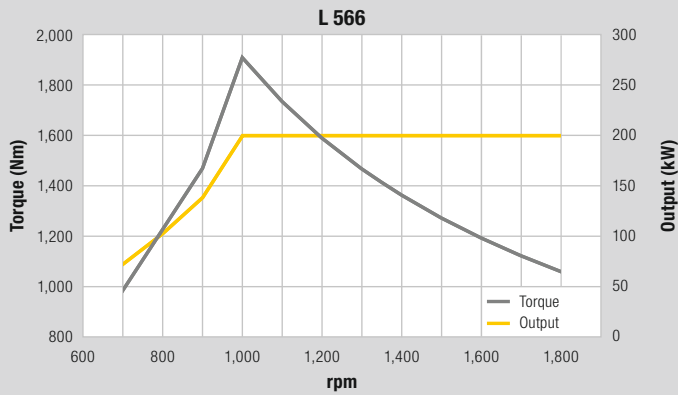

Axles

	L 566	L 576	L 580	L 586
Four-wheel drive				
Front axle	Fixed			
Rear axle	Centre pivot, with 13° oscillating angle to each side			
Height of obstacles which can be driven over	mm 492	473	473	523
	with all four wheels remaining in contact with the ground			
Differentials	Automatic limited-slip differentials			
Reduction gear	Planetary final drive in wheel hubs			
Track width	2,230 mm with all types of tyres (L 566, L 576, L 580) 2,440 mm with all types of tyres (L 586)			

Brakes

Wear-free service brake	Self-locking of the XPower® driveline (acting on all four wheels) and additional pump-accumulator brake system with wet multi-disc brakes (two separate brake circuits)
Parking brake	Electro-hydraulically actuated spring-loaded disc brake system on the transmission

The braking system meets the requirements of the EC guidelines 71/320.

Steering

Design	“Load-sensing” swash plate type variable flow pump with pressure cut-off and flow control. Central pivot with two double-acting, damped steering cylinders
Angle of articulation	38° to each side (L 566, L 576, L 580) 37° to each side (L 586)
Emergency steering	Electro-hydraulic emergency steering system

Attachment Hydraulics

	L 566	L 576	L 580	L 586
Design	“Load-sensing” swash plate type variable flow pump with output and flow control, and pressure cut-off in the control block			
Cooling	Hydraulic oil cooling using thermostatically controlled fan and oil cooler			
Filtration	Return line filter in the hydraulic reservoir			
Control	Liebherr control lever, electro-hydraulically operated			
Lift circuit	Lifting, neutral, lowering Automatic hoisting and lowering by Liebherr control lever Float position controlled by Liebherr control lever			
Tilt circuit	Tilt back, neutral, dump Automatic bucket return for tilting back and dumping controlled by Liebherr control lever			
Max. flow	l/min. 290	290	320	410
Max. pressure				
Z-bar linkage	bar 350	380	380	330
Industrial lift arm	bar 380		380	

Attachment

	L 566	L 576	L 580	L 586		
Geometry variants						
Optional	Powerful Z-bar linkage with tilt cylinder and cast steel cross-tube Industrial lift arm with tilt cylinder, hydraulic quick hitch as standard (L 566, L 580)					
Bearings	Sealed					
Cycle time at nominal load	ZK	IND	ZK	ZK	IND	ZK
Lifting	s 5.5	5.5	5.5	6.1	6.1	6.5
Dumping	s 2.0	3.0	2.0	2.0	3.2	3.0
Lowering (empty)	s 3.5	3.5	3.5	3.5	3.5	4.0

Operator's Cab

Design	Hydraulically mounted, noise-proof cab ROPS roll over protection per EN ISO 3471/EN 474-1 FOPS falling objects protection per EN ISO 3449/EN 474-1, Cat. II Operator's door with sliding side window, sliding side window on right, front windscreen made of compound safety glass, side panels with single-pane safety glass ESG, heated rear window ESG, all windows are tinted. 3 way continuous adjustable steering column
Liebherr operator's seat	6 way adjustable, vibration-damped operator's seat “Comfort” with seat, depth and incline adjustment as standard (air-cushioned with seat heating adjustable to operator's weight), Liebherr control lever mounted into the operator's seat as standard
Cab heating and ventilation	4-zone air conditioning with new improved cooling output as standard, all filters are easy to access and replaceable

Sound Level

	L 566	L 576	L 580	L 586
Sound pressure level to ISO 6396				
L _{PA} (inside cab)	dB(A) 68	68	68	68
Sound power level to 2000/14/EC				
L _{WA} (surround noise)	dB(A) 105	105	105	107

Capacities

	L 566	L 576	L 580	L 586
Fuel tank	l 365	365	365	500
Engine oil (inclusive filter change)	l 40	40	40	40
DEF tank	l 67.5	67.5	67.5	67.5
Pump distribution gearbox	l 1.2	1.2	1.2	1.2
XPower® gearbox	l 55	55	55	55
Coolant	l 73	73	73	73
Front axle	l 42	58	58	60
Rear axle	l 42	42	58	60
Hydraulic tank	l 105	105	105	95
Hydraulic system, total	l 190	190	190	210
Air conditioning system R134a	g 1,250	1,250	1,250	1,250

Dimensions

Z-bar Linkage

L 566 – L 586

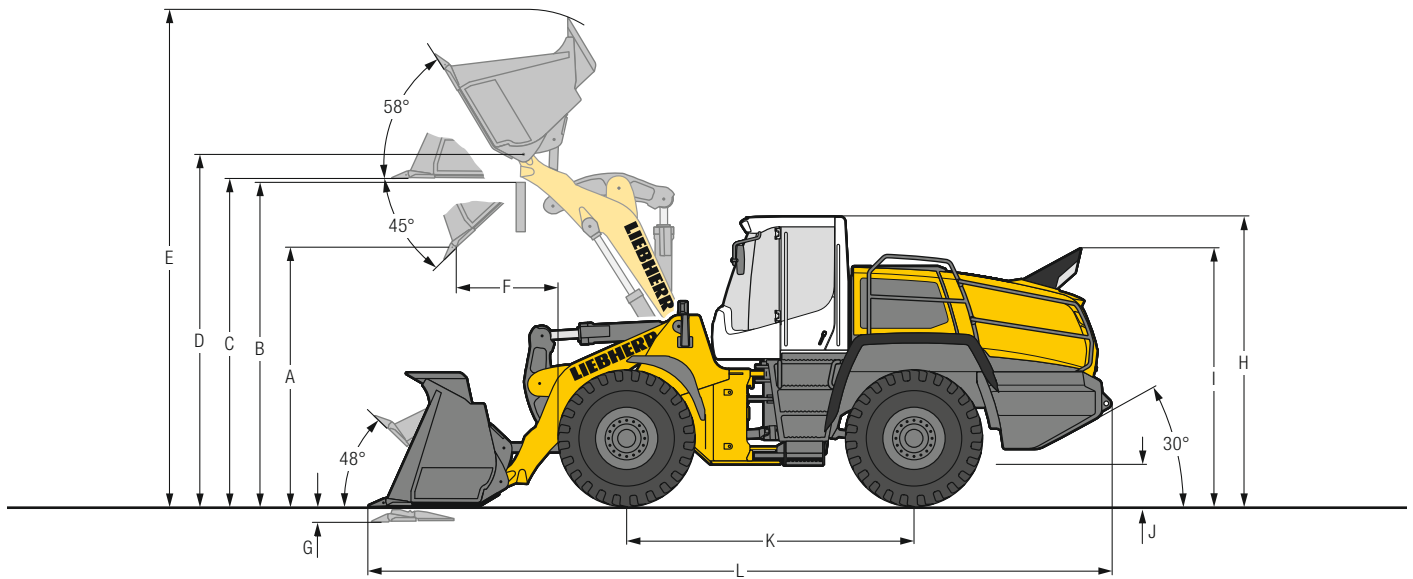

Loading Bucket



	L 566		L 576		L 580			L 586		
	ZK	ZK	ZK	ZK	ZK	ZK	BOCE	ZK	ZK	ZK
Geometry	T	T	T	T	T	T	BOCE	T	T	ROB
Cutting tools										
Lift arm length	mm	2,920	2,920	3,050	3,050	3,050	3,050	3,050	3,150	3,150
Bucket capacity according to ISO 7546**	m ³	4.2	4.7	4.7	5.2	5.2	5.7	5.7 ¹⁾	6.0	6.5
Specific material density	t/m ³	1.8	1.6	1.8	1.6	1.8	1.6	1.7	1.8	1.6
Bucket width	mm	3,000	3,000	3,000	3,000	3,000	3,300	3,300	3,430	3,400
A Dumping height at max. lift height and 45° discharge	mm	3,205	3,130	3,355	3,285	3,285	3,220	3,220	3,260	3,260
B Dump-over height	mm	3,900	3,900	4,100	4,100	4,100	4,100	4,100	4,150	4,150
C Max. height of bucket bottom	mm	4,050	4,050	4,270	4,270	4,270	4,270	4,270	4,330	4,330
D Max. height of bucket pivot point	mm	4,360	4,360	4,580	4,580	4,580	4,580	4,580	4,640	4,640
E Max. operating height	mm	6,120	6,220	6,440	6,540	6,540	6,500	6,500	6,530	6,450
F Reach at max. lift height and 45° discharge	mm	1,190	1,270	1,135	1,205	1,205	1,285	1,285	1,430	1,430
G Digging depth	mm	100	100	100	100	100	100	100	100	140
H Height above operator's cab	mm	3,590	3,590	3,590	3,590	3,590	3,590	3,590	3,740	3,740
I Height above exhaust	mm	3,200	3,200	3,200	3,200	3,200	3,200	3,200	3,300	3,300
J Ground clearance	mm	535	535	540	540	465	465	465	575	575
K Wheelbase	mm	3,560	3,560	3,630	3,630	3,710	3,710	3,710	3,900	3,900
L Overall length	mm	9,165	9,275	9,445	9,545	9,620	9,720	9,720	9,980	9,980
Turning circle radius over outside bucket edge	mm	7,340	7,370	7,500	7,530	7,615	7,780	7,780	8,350	8,300
Breakout force (SAE)	kN	200	190	200	190	225	205	200	240	240
Tipping load, straight*	kg	18,150	17,900	20,100	19,900	21,750	21,250	22,200	24,500	23,900
Tipping load, fully articulated*	kg	15,900	15,650	17,600	17,400	19,200	18,700	19,500	21,600	21,000
Operating weight*	kg	23,900	24,000	25,700	25,800	27,650	27,800	28,800	32,600	33,050
Tyre size		26.5R25 L3		26.5R25 L3		26.5R25 L3			29.5R25 L3	

* The figures shown include the above tyres, all lubricants, a full fuel tank, the ROPS/FOPS cab and the operator.

Different tyres and optional equipment will change the operating weight and tipping load. (Tipping load, fully articulated according to ISO 14397-1)

** Actual bucket capacity may be approx. 10% larger than the calculation according to ISO 7546 standard.

The degree to which the bucket can be filled depends on the material – see pages 34/35.

¹⁾ Toothed buckets, hydraulic quick hitch and additional hydraulic circuits are not approved for rehandling application.

= Excavation bucket with back grading edge for direct mounting

= Rehandling bucket for direct mounting

= Rock bucket with oblique base for quarrying applications for direct mounting

ZK = Z-bar linkage

T = Welded-on tooth holder with add-on teeth

BOCE = Bolt-on cutting edge

ROB = Rock bucket with delta cutting edge, welded-on tooth holder with add-on teeth and bolted intermediate sections

Dimensions

Z-bar Linkage High Lift

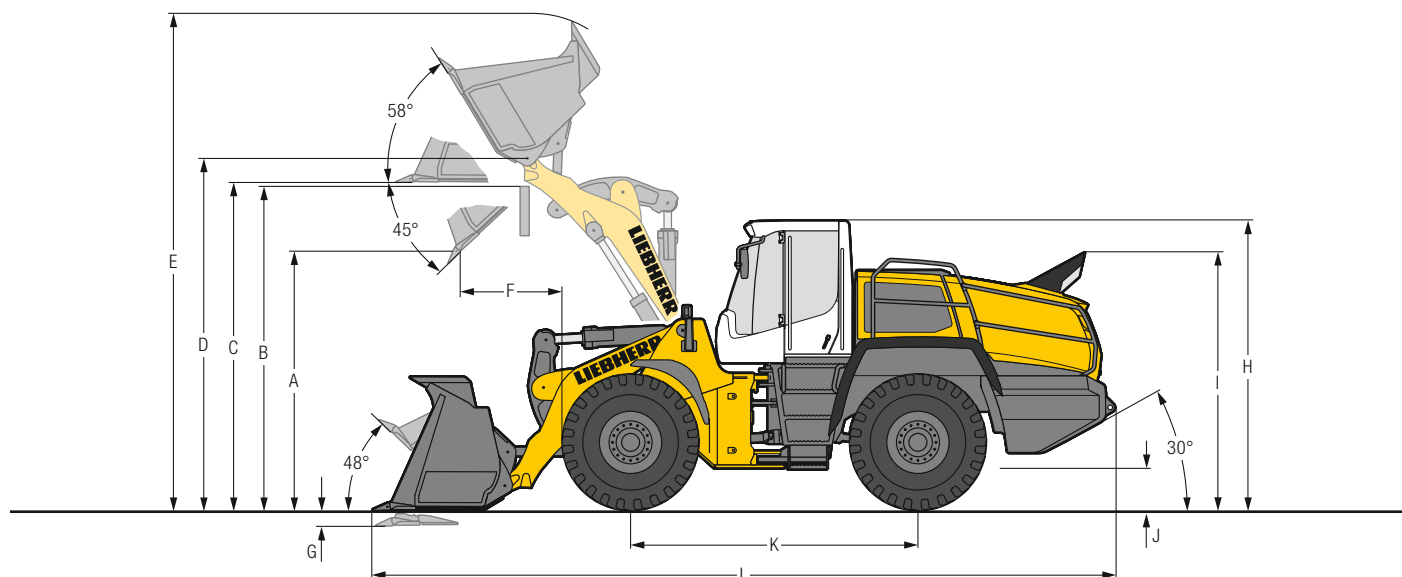

L 566 – L 586

Loading Bucket

	L 566		L 576		L 580			L 586		
Geometry	ZK	ZK	ZK	ZK	ZK	ZK	ZK	ZK	ZK	ZK
Cutting tools	T	T	ZK	ZK	T	T	BOCE	T	T	ROB
Lift arm length	mm	3,250	3,250	3,250	3,250	3,250	3,250	3,450	3,450	3,450
Bucket capacity according to ISO 7546**	m ³	3.7	4.2	4.2	4.7	4.7	5.2	5.2 ¹⁾	5.5	6.0
Specific material density	t/m ³	1.8	1.6	1.8	1.6	1.8	1.6	1.7	1.8	1.6
Bucket width	mm	3,000	3,000	3,000	3,000	3,000	3,000	3,000	3,400	3,400
A Dumping height at max. lift height and 45° discharge	mm	3,720	3,650	3,650	3,575	3,560	3,490	3,425	3,725	3,670
B Dump-over height	mm	4,300	4,300	4,300	4,300	4,300	4,300	4,300	4,500	4,500
C Max. height of bucket bottom	mm	4,470	4,470	4,470	4,470	4,470	4,470	4,470	4,750	4,770
D Max. height of bucket pivot point	mm	4,780	4,780	4,780	4,780	4,780	4,780	4,780	5,060	5,080
E Max. operating height	mm	6,460	6,555	6,555	6,650	6,650	6,740	6,700	6,950	6,800
F Reach at max. lift height and 45° discharge	mm	1,130	1,200	1,130	1,215	1,190	1,265	1,340	1,370	1,410
G Digging depth	mm	140	140	140	140	140	140	140	100	100
H Height above operator's cab	mm	3,590	3,590	3,590	3,590	3,590	3,590	3,590	3,740	3,760
I Height above exhaust	mm	3,200	3,200	3,200	3,200	3,200	3,200	3,200	3,300	3,320
J Ground clearance	mm	535	535	540	540	465	465	465	575	575
K Wheelbase	mm	3,560	3,560	3,630	3,630	3,710	3,710	3,710	3,900	3,900
L Overall length	mm	9,500	9,590	9,590	9,700	9,770	9,870	9,970	10,250	10,280
Turning circle radius over outside bucket edge	mm	7,480	7,510	7,560	7,590	7,680	7,710	7,740	8,500	8,450
Breakout force (SAE)	kN	210	200	210	200	240	225	225	250	240
Tipping load, straight*	kg	15,850	15,650	18,650	18,550	20,200	20,000	20,600	22,400	21,700
Tipping load, fully articulated*	kg	13,850	13,650	16,350	16,250	17,800	17,600	18,200	19,700	19,000
Operating weight*	kg	24,000	24,100	25,650	25,750	27,650	27,750	28,600	32,600	33,000
Tyre size		26.5R25 L3		26.5R25 L3		26.5R25 L3			29.5R25 L3	



* The figures shown include the above tyres, all lubricants, a full fuel tank, the ROPS/FOPS cab and the operator.

Different tyres and optional equipment will change the operating weight and tipping load. (Tipping load, fully articulated according to ISO 14397-1)

** Actual bucket capacity may be approx. 10% larger than the calculation according to ISO 7546 standard.

The degree to which the bucket can be filled depends on the material – see pages 34/35.

¹⁾ Toothed buckets, hydraulic quick hitch and additional hydraulic circuits are not approved for rehandling application.

-  = Excavation bucket with back grading edge for direct mounting
-  = Rehandling bucket for direct mounting
-  = Rock bucket with oblique base for quarrying applications for direct mounting

- ZK = Z-bar linkage
- T = Welded-on tooth holder with add-on teeth
- BOCE = Bolt-on cutting edge
- ROB = Rock bucket with delta cutting edge, welded-on tooth holder with add-on teeth and bolted intermediate sections

Dimensions

Industrial Lift Arm

L 566 – L 586

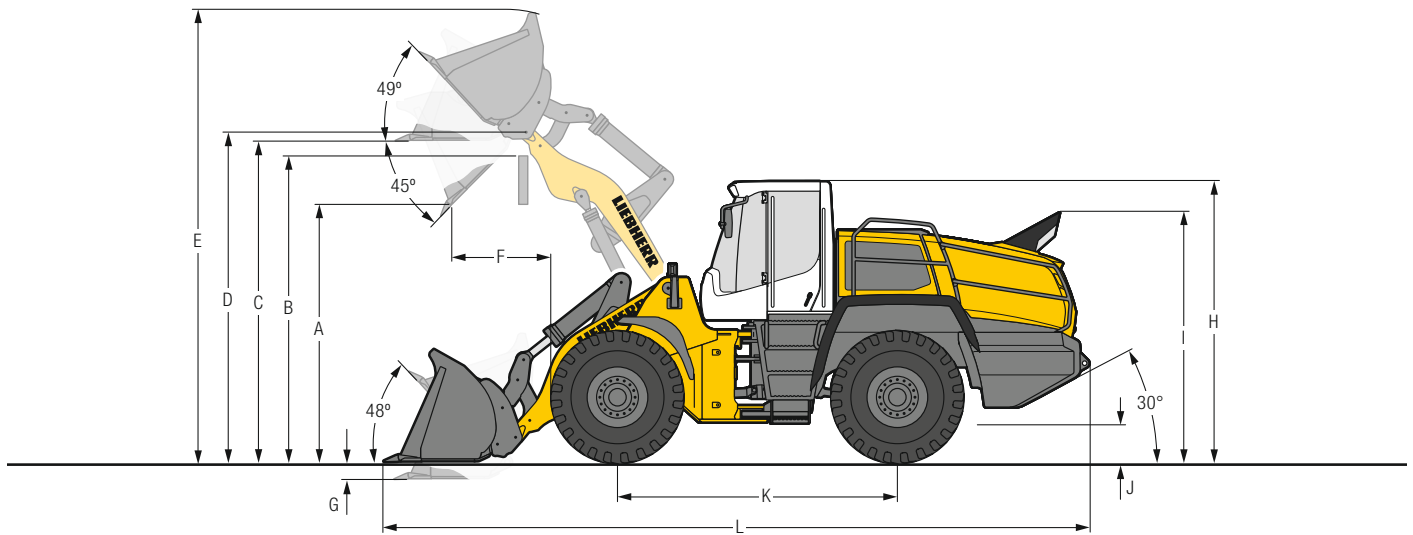

Excavation Bucket



	L 566		L 580	
	IND-QH	IND-QH	IND-QH	IND-QH
Geometry				
Cutting tools	T	T	T	T
Lift arm length	mm 2,900	2,900	2,900	2,900
Bucket capacity according to ISO 7546**	m ³ 3.5	4.0	4.5	5.0
Specific material density	t/m ³ 1.8	1.6	1.8	1.6
Bucket width	mm 3,000	3,000	3,000	3,000
A Dumping height at max. lift height and 45° discharge	mm 3,210	3,140	3,070	3,000
B Dump-over height	mm 3,900	3,900	3,900	3,900
C Max. height of bucket bottom	mm 4,145	4,145	4,145	4,145
D Max. height of bucket pivot point	mm 4,490	4,490	4,490	4,490
E Max. operating height	mm 6,045	6,165	6,265	6,330
F Reach at max. lift height and 45° discharge	mm 1,270	1,340	1,290	1,230
G Digging depth	mm 100	100	100	100
H Height above operator's cab	mm 3,590	3,590	3,590	3,590
I Height above exhaust	mm 3,200	3,200	3,200	3,200
J Ground clearance	mm 535	535	465	465
K Wheelbase	mm 3,630	3,630	3,710	3,710
L Overall length	mm 9,270	9,370	9,545	9,650
Turning circle radius over outside bucket edge	mm 7,410	7,440	7,560	7,590
Breakout force (SAE)	kN 200	185	200	185
Tipping load, straight*	kg 17,100	16,650	20,150	19,700
Tipping load, fully articulated*	kg 15,000	14,550	17,750	17,300
Operating weight*	kg 24,800	24,950	28,050	28,200
Tyre size	26.5R25 L3		26.5R25 L3	

* The figures shown include the above tyres, all lubricants, a full fuel tank, the ROPS/FOPS cab and the operator.

Different tyres and optional equipment will change the operating weight and tipping load. (Tipping load, fully articulated according to ISO 14397-1)

** Actual bucket capacity may be approx. 10% larger than the calculation according to ISO 7546 standard.

The degree to which the bucket can be filled depends on the material – see pages 34/35.

IND-QH = Industrial lift arm with parallel guidance incl. quick hitch

T = Welded-on tooth holder with add-on teeth

Attachment

Light Material Bucket and High-Dump Bucket

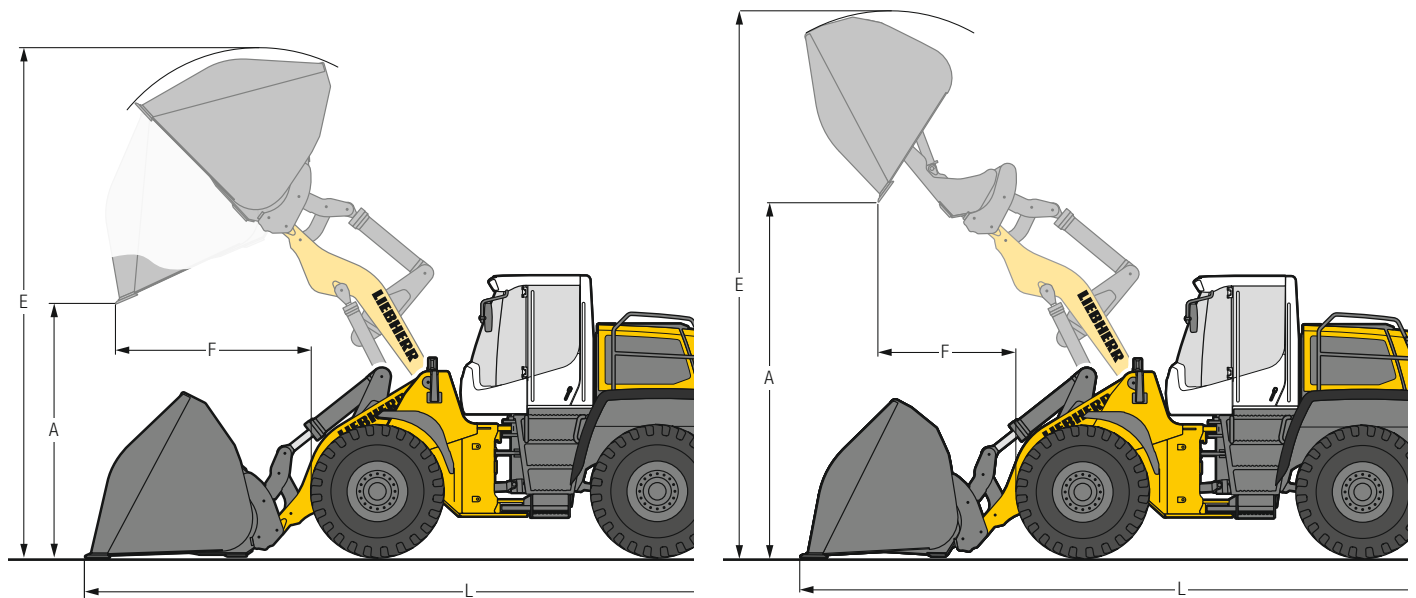

L 566 – L 586

Light Material Bucket

		L 566		L 580		L 586
		IND-QH	IND-QH	IND-QH	IND-QH	ZK
Geometry		IND-QH	IND-QH	IND-QH	IND-QH	ZK
Cutting tools		BOCE	BOCE	BOCE	BOCE	BOCE
Bucket capacity	m ³	6.5	12.0	7.5	14.0	8.5
Specific material density	t/m ³	1.0	0.45	1.0	0.45	1.1
Bucket width	mm	3,200	3,700	3,400	4,000	3,500
A Dumping height at max. lift height	mm	2,885	2,620	2,810	2,480	2,940
E Max. operating height	mm	6,470	6,700	6,580	6,800	6,835
F Reach at maximum lift height	mm	1,485	1,860	1,550	1,950	1,770
L Overall length	mm	9,545	10,025	9,715	10,200	10,200
Tipping load, straight*	kg	15,700	14,600	19,300	17,900	24,000
Tipping load, fully articulated*	kg	13,700	12,600	16,900	15,500	21,000
Operating weight*	kg	25,350	26,300	28,650	29,600	32,800
Tyre size		26.5R25 L3		26.5R25 L3		29.5R25 L3

High-Dump Bucket

		L 566		L 580		L 586
		IND-QH	IND-QH	IND-QH	IND-QH	ZK
Geometry		IND-QH	IND-QH	IND-QH	IND-QH	ZK
Cutting tools		BOCE	BOCE	BOCE	BOCE	BOCE
Bucket capacity	m ³	6.0	11.0	7.0	13.0	8.5
Specific material density	t/m ³	1.0	0.45	1.0	0.45	1.0
Bucket width	mm	3,200	3,700	3,200	4,000	3,500
A Dumping height at max. lift height	mm	5,130	4,840	4,970	4,780	5,100
E Max. operating height	mm	7,215	7,490	7,420	7,650	7,700
F Reach at maximum lift height	mm	1,780	2,140	2,040	2,060	2,000
L Overall length	mm	9,815	10,125	10,060	10,300	10,500
Tipping load, straight*	kg	14,700	14,100	17,800	17,100	23,200
Tipping load, fully articulated*	kg	12,700	12,100	15,500	14,800	20,300
Operating weight*	kg	26,000	26,900	29,100	30,100	33,500
Tyre size		26.5R25 L3		26.5R25 L3		29.5R25 L3

* The figures shown include the above tyres, all lubricants, a full fuel tank, the ROPS/FOPS cab and the operator.

Different tyres and optional equipment will change the operating weight and tipping load. (Tipping load, fully articulated according to ISO 14397-1)

IND-QH = Industrial lift arm with parallel guidance incl. quick hitch

ZK = Z-bar linkage

BOCE = Bolt-on cutting edge

Attachment

Fork Carrier and Fork

L 566 – L 586

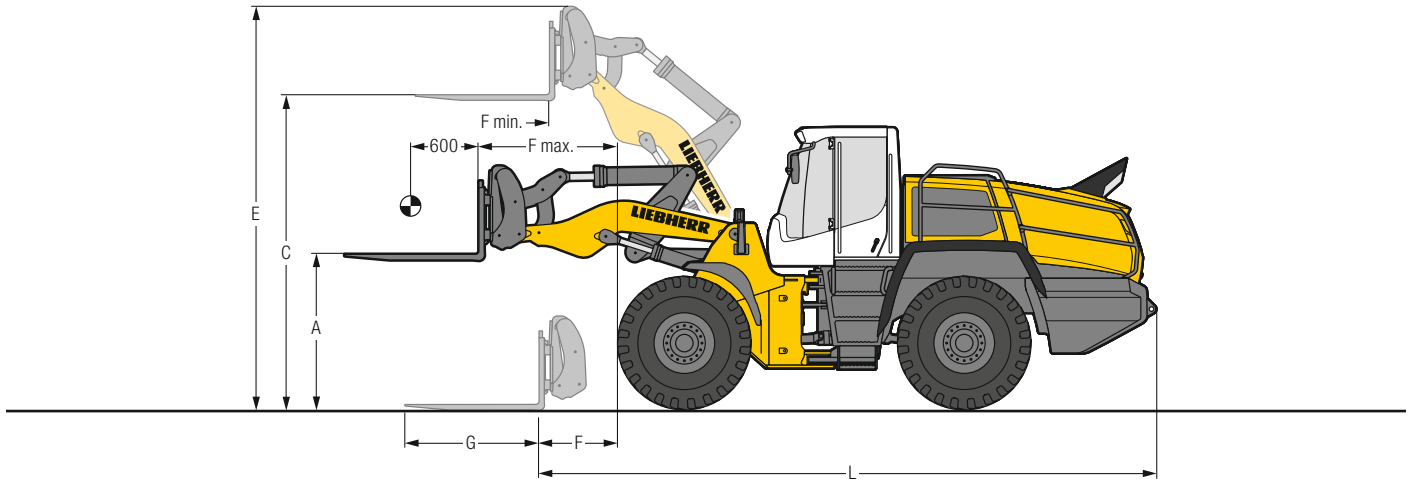

FEM IV Fork Carrier and Fork



		L 566	L 580
	Geometry	IND-QH	IND-QH
A	Lifting height at max. reach	2,075	2,075
C	Max. lifting height	4,220	4,220
E	Max. operating height	5,200	5,200
F	Reach at loading position	1,145	1,025
F max.	Max. reach	1,925	1,805
F min.	Reach at max. lifting height	980	860
G	Fork length	1,800	1,800
L	Length – basic machine	8,100	8,170
	Tipping load, straight*	13,500	16,300
	Tipping load, fully articulated*	11,900	14,400
	Recommended payload for uneven ground = 60% of tipping load, articulated¹⁾	7,140	9,780
	Recommended payload for smooth surfaces = 80% of tipping load, articulated¹⁾	9,520	10,000 ²⁾
	Operating weight*	23,950	26,900
	Tyre size	26.5R25 L3	26.5R25 L3

* The figures shown include the above tyres, all lubricants, a full fuel tank, the ROPS/FOPS cab and the operator.

Different tyres and optional equipment will change the operating weight and tipping load. (Tipping load, fully articulated according to ISO 14397-1)

¹⁾ According to EN 474-3

²⁾ Payload is limited by FEM IV fork carrier and forks

IND-QH = Industrial lift arm with parallel guidance incl. quick hitch

Attachment

Log Grapple

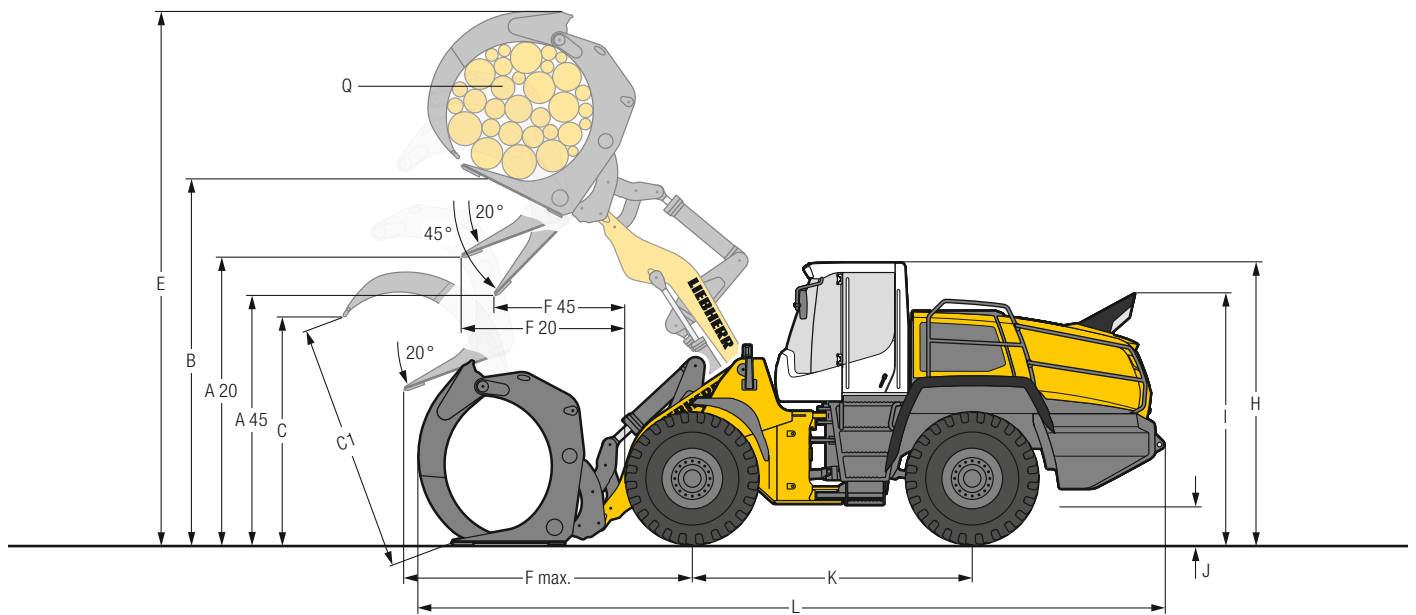

L 566 – L 586

Log Grapple



		L 566	L 580
	Geometry	IND-QH	IND-QH
A20	Discharge height at 20°	3,570	3,520
A45	Discharge height at 45°	2,930	2,805
B	Manipulation height	5,125	5,125
C	Max. grapple opening in loading position	2,650	2,930
C1	Max. grapple opening	3,050	3,340
E	Max. height	7,400	7,500
F20	Reach at max. lifting height at 20° discharge	2,165	2,215
F45	Reach at max. lifting height at 45° discharge	1,620	1,625
F max.	Max. reach	3,110	3,160
H	Height above operator's cab	3,615	3,615
I	Height above exhaust	3,225	3,225
J	Ground clearance	555	485
K	Wheelbase	3,630	3,710
L	Overall length	9,810	10,050
	Width over tyres	2,970	2,970
Q	Grapple diameter	3.1	3.5
	Grapple width	1,800	1,800
	Payload*	8,200	9,200
	Operating weight*	26,950	29,850
	Tyre size	26.5R25 L4	26.5R25 L4

* The figures shown include the above tyres, all lubricants, a full fuel tank, the ROPS/FOPS cab and the operator. Different tyres and optional equipment will change the operating weight and payload.

IND-QH = Industrial lift arm with parallel guidance incl. quick hitch

Bucket Selection

L 566

Lift arm	Bucket	Material density (t/m³)																	
		0.4	0.6	0.8	1.0	1.2	1.4	1.6	1.8	2.0									
ZK	GPB ₁	4.2 m³							4.6	4.2									
		4.7 m³							5.2										
ZK-HL	GPB ₁	3.7 m³							4.1										
		4.2 m³							4.6										
IND-QH	GPB ₁	3.5 m³							3.9										
		4.0 m³							4.4										
	LMB	6.5 m³				7.2													
		12.0 m³	12.0																
	HDB	6.0 m³				6.6													
		11.0 m³	11.0																

L 576

Lift arm	Bucket	Material density (t/m³)																	
		0.4	0.6	0.8	1.0	1.2	1.4	1.6	1.8	2.0									
ZK	GPB ₁	4.7 m³								5.2									
		5.2 m³								5.7									
ZK-HL	GPB ₁	4.2 m³								4.6									
		4.7 m³								5.2									

L 580

Lift arm	Bucket	Material density (t/m³)																	
		0.4	0.6	0.8	1.0	1.2	1.4	1.6	1.8	2.0									
ZK	GPB ₁	5.2 m³								5.7									
		5.7 m³								6.3									
		5.7 m³*								6.3									
ZK-HL	GPB ₁	4.7 m³								5.2									
		5.2 m³								5.7									
	GPB ₂	5.2 m³*								5.7									
IND-QH	GPB ₁	4.5 m³								5.0									
		5.0 m³								5.5									
	LMB	7.5 m³				8.3													
		14.0 m³	14.0																
	HDB	7.0 m³				7.7													
		13.0 m³	13.0																

L 586

Lift arm	Bucket	Material density (t/m³)																	
		0.4	0.6	0.8	1.0	1.2	1.4	1.6	1.8	2.0									
ZK	GPB ₂	6.0 m³								6.6									
		6.5 m³								7.2									
	RB	5.5 m³									6.1								
		LMB	8.5 m³				9.4												
ZK-HL	HDB	8.5 m³				9.4													
		GPB ₂	5.5 m³								6.1								
6.0 m³									6.6										
RB	5.0 m³									5.5									

* Toothed buckets, hydraulic quick hitch and additional hydraulic circuits are not approved for rehandling application.

Bucket Selection

Bucket Filling Factor

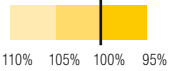

Lift Arm

ZK	Z-bar linkage, standard lift arm length
IND-QH	Industrial lift arm with quick hitch, standard lift arm length
ZK-HL	Z-bar linkage, High Lift

Bucket

GPB₁	General purpose bucket (Excavation bucket)
GPB₂	General purpose bucket (Rehandling bucket)
RB	Rock bucket
LMB	Light material bucket
HDB	High-dump bucket

Bulk Material Densities and Bucket Filling Factors

		t/m ³	%			t/m ³	%			t/m ³	%
Gravel	moist	1.9	105	Earth	dry	1.3	115	Glass waste	broken	1.4	100
	dry	1.6	105		wet excavated	1.6	110		solid	1.0	100
	crushed stone	1.5	100	Topsoil		1.1	110	Compost	dry	0.8	105
Sand	dry	1.5	105	Basalt		1.95	100	wet	1.0	110	
	wet	1.9	110	Granite		1.8	95	Wood chips/Saw dust		0.5	110
Gravel and Sand	dry	1.7	105	Sandstone		1.6	100	Paper	shredded/loose	0.6	110
	wet	2.0	100	Slate		1.75	100	recovered paper/cardboard	1.0	110	
Sand/Clay		1.6	110	Bauxite		1.4	100	Coal	heavy material density	1.2	110
Clay	natural	1.6	110	Limestone		1.6	100		light material density	0.9	110
	dry	1.4	110	Gypsum	broken	1.8	100	Waste	domestic waste	0.5	100
Clay/Gravel	dry	1.4	110	Coke		0.5	110		bulky waste	1.0	100
	wet	1.6	100	Slag	broken	1.8	100				

Tipping Load



What is tipping load?

Load at centre of gravity of working equipment, so that the wheel loader just begins to tip over the front axle. This is the most unfavourable static-load position for the wheel loader. Lifting arms horizontal, wheel loader fully articulated at centre pivot.

Pay load.

The pay load must not exceed 50% of the tipping load when articulated. This is equivalent to a static stability-margin factor of 2.0.

Bucket capacity.

The bucket volume is determined from the pay load.

$$\text{Pay load} = \frac{\text{Tipping load, articulated}}{2}$$

$$\text{Bucket capacity} = \frac{\text{Pay load (t)}}{\text{Specific bulk weight of material (t/m}^3\text{)}}$$



Tyre Types

	Size and tread code		Change of operating weight kg	Width over tyres mm	Change in vertical dimensions* mm	Use
L 566 XPower®						
Bridgestone	26.5R25 VJT L3		160	2,970	14	Bulk material (firm ground conditions)
Bridgestone	26.5R25 VLTS L4		420	2,970	44	Gravel, Industry (firm ground conditions)
Bridgestone	26.5R25 VSDT L5		1,038	2,970	50	Stone, Mining spoil (firm ground conditions)
Bridgestone	26.5R25 VSDL L5		1,290	2,970	57	Stone, Scrap, Recycling (firm ground conditions)
Bridgestone	26.5R25 VSMS L5		1,599	2,960	70	Scrap, Recycling, Slag (firm ground conditions)
Bridgestone	26.5R25 VSNT L4		576	2,960	47	Gravel, Industry, Wood (firm ground conditions)
Bridgestone	750/65R25 VTS L3		194	3,070	- 39	Gravel, Industry, Wood (all ground conditions)
Goodyear	26.5R25 RT-3B L3		324	2,980	26	Gravel (all ground conditions)
Goodyear	26.5R25 TL-3A+ L3		348	2,980	30	Sand, Gravel, Earthworks, Clay (all ground conditions)
Goodyear	26.5R25 GP-4D L4		436	2,980	26	Gravel, Industry, Wood (firm ground conditions)
Goodyear	26.5R25 RL-4K L4		776	2,990	63	Gravel, Industry, Stone (firm ground conditions)
Goodyear	26.5R25 RL-5K L5		1,244	2,990	63	Stone, Scrap, Recycling (firm ground conditions)
Goodyear	26.5R25 RL-5S L5		1,460	2,990	63	Scrap, Recycling, Slag (firm ground conditions)
Goodyear	26.5R25 RT-5D L5		1,008	2,990	63	Stone, Mining spoil (firm ground conditions)
Goodyear	750/65R25 TL-3A+ L3		148	3,100	- 26	Sand, Gravel, Industry, Wood (all ground conditions)
Michelin	26.5R25 XHA2 L3		0	2,960	0	Sand, Gravel (all ground conditions)
Michelin	26.5R25 XMINE L5		1,104	3,000	68	Stone, Scrap, Recycling (firm ground conditions)
Michelin	26.5R25 XLD D2A L5		696	2,970	38	Stone, Mining spoil (firm ground conditions)
Michelin	26.5R25 XTXL L4		488	2,970	23	Gravel, Industry, Wood (firm ground conditions)
Michelin	750/65R25 XLD 65 L3		- 8	3,060	- 57	Gravel, Industry, Wood (all ground conditions)
L 576 XPower® / L 580 XPower®						
Bridgestone	26.5R25 VJT L3		160	2,970	14	Bulk material (firm ground conditions)
Bridgestone	26.5R25 VSDT L5		1,038	2,970	50	Stone, Mining spoil (firm ground conditions)
Bridgestone	26.5R25 VSDL L5		1,290	2,970	57	Stone, Scrap, Recycling (firm ground conditions)
Bridgestone	26.5R25 VSMS L5		1,599	2,960	70	Scrap, Recycling, Slag (firm ground conditions)
Bridgestone	26.5R25 VSNT L4		576	2,960	47	Gravel, Industry, Wood (firm ground conditions)
Bridgestone	750/65R25 VTS L3		86	3,070	- 39	Gravel, Industry, Wood (all ground conditions)
Goodyear	26.5R25 RT-3B L3		324	2,980	26	Gravel (all ground conditions)
Goodyear	26.5R25 TL-3A+ L3		348	2,980	30	Sand, Gravel, Earthworks, Clay (all ground conditions)
Goodyear	26.5R25 GP-4D L4		436	2,980	26	Gravel, Industry, Wood (firm ground conditions)
Goodyear	26.5R25 RL-4K L4		776	2,990	63	Gravel, Industry, Stone (firm ground conditions)
Goodyear	26.5R25 RL-5K L5		1,244	2,990	63	Stone, Scrap, Recycling (firm ground conditions)
Goodyear	26.5R25 RL-5S L5		1,460	2,990	63	Scrap, Recycling, Slag (firm ground conditions)
Goodyear	26.5R25 RT-5D L5		1,008	2,990	63	Stone, Mining spoil (firm ground conditions)
Goodyear	750/65R25 TL-3A+ L3		40	3,100	- 26	Sand, Gravel, Industry, Wood (all ground conditions)
Michelin	26.5R25 XHA2 L3		0	2,960	0	Sand, Gravel (all ground conditions)
Michelin	26.5R25 XMINE L5		1,104	3,000	68	Stone, Scrap, Recycling (firm ground conditions)
Michelin	26.5R25 XLD D2A L5		696	2,970	38	Stone, Mining spoil (firm ground conditions)
Michelin	26.5R25 XTXL L4		488	2,970	23	Gravel, Industry, Wood (firm ground conditions)
Michelin	750/65R25 XLD 65 L3		- 116	3,060	- 57	Gravel, Industry, Wood (all ground conditions)
L 586 XPower®						
Bridgestone	29.5R25 VJT L3		146	3,260	15	Bulk material (firm ground conditions)
Bridgestone	29.5R25 VSDT L5		1,370	3,270	50	Stone, Mining spoil (firm ground conditions)
Bridgestone	29.5R25 VSDL L5		1,730	3,270	60	Stone, Scrap, Recycling (firm ground conditions)
Bridgestone	29.5R25 VSNT L4		712	3,270	50	Gravel, Industry, Wood (firm ground conditions)
Goodyear	29.5R25 TL-3A+ L3		532	3,290	36	Sand, Gravel, Earthworks, Clay (all ground conditions)
Goodyear	29.5R25 GP-4D L4		504	3,260	24	Gravel, Industry, Wood (firm ground conditions)
Goodyear	29.5R25 RL-4K L4		1,124	3,270	44	Gravel, Industry, Stone (firm ground conditions)
Goodyear	29.5R25 RL-5K L5		1,600	3,310	66	Stone, Scrap, Recycling (firm ground conditions)
Goodyear	29.5R25 RT-5D L5		1,508	3,300	56	Stone, Mining spoil (firm ground conditions)
Goodyear	29.5R25 RL-5S L5		2,100	3,270	66	Scrap, Recycling, Slag (firm ground conditions)
Michelin	29.5R25 XHA2 L3		0	3,250	0	Sand, Gravel (all ground conditions)
Michelin	29.5R25 XLD D2A L5		936	3,260	26	Stone, Mining spoil (firm ground conditions)
Michelin	29.5R25 XTXL L4		606	3,280	26	Gravel, Industry, Wood (firm ground conditions)
Michelin	29.5R25 XMINE L5		1,316	3,300	55	Stone, Scrap, Recycling (firm ground conditions)

*The stated values are theoretical and may deviate in practice.

Before operating the vehicle with tyre foam filling or tyre protection chains, please discuss this with the Liebherr-Werk Bischofshofen GmbH.

The Liebherr Wheel Loaders

Wheel Loader



		L 506 Compact	L 507 Stereo	L 508 Compact	L 509 Stereo	L 514 Stereo
Tipping load	kg	3,450	3,712	3,850	4,430	5,750
Bucket capacity	m ³	0.8	0.9	1.0	1.2	1.5
Operating weight	kg	5,180	5,470	5,600	6,390	8,860
Engine output (ISO 14396)	kW / HP	46/63	50/68	50/68	54/73	76/103

Wheel Loader



		L 518 Stereo	L 526	L 538	L 546	L 550 XPower®
Tipping load	kg	6,550	7,700	9,500	10,500	12,200
Bucket capacity	m ³	1.7	2.1	2.6	2.8	3.2
Operating weight	kg	9,190	11,250	13,500	14,200	17,700
Engine output (ISO 14396)	kW / HP	76/103	100/136	111/151	120/163	140/191

Wheel Loader



		L 556 XPower®	L 566 XPower®	L 576 XPower®	L 580 XPower®	L 586 XPower®
Tipping load	kg	13,700	15,900	17,600	19,200	21,600
Bucket capacity	m ³	3.6	4.2	4.7	5.2	6.0
Operating weight	kg	18,400	23,900	25,700	27,650	32,600
Engine output (ISO 14396)	kW / HP	165/224	200/272	215/292	230/313	260/354

06.17

Environmental Protection Can Help You Earn Money!

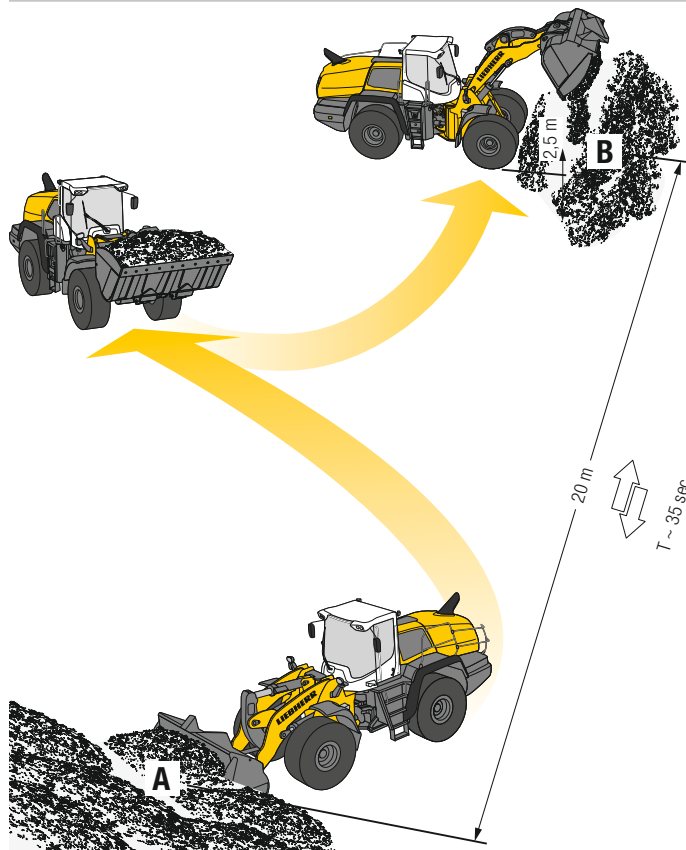

The Liebherr Standard Consumption Test – easy to reproduce and practical.

The Liebherr Standard Consumption Test determines the number of loading cycles that can be carried out with 5 litres of diesel. The material is taken from pile A and carried over a distance of 20 metres to point B. The time needed for each working cycle should be 35 seconds. Discharge at point B should take place from a height of 2.5 m. The working cycles continue until the 5 litres of diesel in the external measuring tank have been used up. The loader's fuel consumption per operating hour is calculated as follows:

$$\frac{400}{\text{Number of loading cycles}} = \text{Consumption per hour}$$

Values for the Liebherr wheel loaders

	Numbers of working cycles	Litres / 100 tons	Litres / hour	Ø Litres / hour*
L 526: 2.1 m ³	n = 48	2.8	8.3	5.9
L 538: 2.6 m ³	n = 40	2.7	10.0	6.6
L 546: 2.8 m ³	n = 38	2.6	10.5	6.8
L 550: 3.2 m ³	n = 32	2.7	12.5	8.7
L 556: 3.6 m ³	n = 29	2.7	13.8	9.6
L 566: 4.2 m ³	n = 22	3.0	18.2	11.6
L 576: 4.7 m ³	n = 21	2.8	19.1	12.1
L 580: 5.2 m ³	n = 20	2.7	20.0	13.2
L 586: 6.0 m ³	n = 15	3.1	26.7	15.9

* Wheel loader in practical customer applications with individual machine configurations. Average data from LiDAT from 12.06.2017.



Experience just how much fuel you can save!
www.encyplus.liebherr.com

Equipment

 Basic Wheel Loader	550	556	566	576	580	586
Crash protection, rear	+	+	+	+	+	+
Automatic central lubrication system	+	+	+	+	+	•
Battery main switch (lockable)	•	•	•	•	•	•
Electronic tractive force regulation for difficult ground conditions	•	•	•	•	•	•
Ride control	•	•	•	•	•	•
Parking brake	•	•	•	•	•	•
Fluff trap for radiator	+	+	+	+	+	+
Speed limiter 20 km/h as a factory preset	+	+	+	+	+	+
Speed limiter V _{max} adjustable key on the control unit	•	•	•	•	•	•
DEF tank	•	•	•	•	•	•
Pre-heat system for cold starting	•	•	•	•	•	•
Rear license panel light	+	+	+	+	+	+
Combined inching-braking system	•	•	•	•	•	•
Mudguard extension	+	+	+	+	+	+
Fuel pre-filter	•	•	•	•	•	•
Fuel pre-filter with pre-heating	+	+	+	+	+	+
Large-mesh radiator	+	+	+	+	+	+
Cooling water pre-heating 230 V	+	+	+	+	+	+
Multi-disc limited slip differentials in both axles	•	•	•	•	•	•
Liebherr biodegradable hydraulic oil	+	+	+	+	+	+
Liebherr-SCR technology	•	•	•	•	•	•
Liebherr-SCR technology incl. diesel particle filter	+	+	+	+	+	+
Reversible fan drive	+	+	+	+	+	+
Widening for mudguard	+	+	+	+	+	-
Widening for mudguard rear (in steel design) and bigger front mudguards	-	-	-	-	-	+
Ramming guard with guard	+	+	+	+	+	-
Headlights halogen (double design on engine hood)	•	•	•	•	•	•
Headlights LED (double design on engine hood)	+	+	+	+	+	+
Guard for headlights	+	+	+	+	+	+
Road travel counterweight	•	•	+	-	-	-
Lockable doors and engine hood	•	•	•	•	•	•
Tunnel package	+	+	+	+	-	-
Chassis protection rear	+	+	+	+	+	+
Chassis protection front	+	+	+	+	+	+
Air pre-cleaner TOP AIR	+	+	+	+	+	+
Toolbox with toolkit	•	•	•	•	•	•
Weigher unit Liebherr (integrated in display unit)	+	+	+	+	+	+
Towing hitch	•	•	•	•	•	•
Additional handrails left	•	•	•	•	•	•
Additional handrails right	+	+	+	+	+	+
Additional heating	+	+	+	+	+	+

 Equipment	550	556	566	576	580	586
Working hydraulics lockout	•	•	•	•	•	•
Automatic hoisting lowering programmable	•	•	•	•	•	•
Automatic bucket return programmable	•	•	•	•	•	•
Fork carrier and pallet forks	+	+	+	+	+	+
High-dump bucket	+	+	+	+	+	+
Log grapple	+	+	+	-	+	-
High Lift arms	+	+	+	+	+	+
Industrial lift arm	+	+	+	-	+	-
Lift arm Z-bar linkage	•	•	•	•	•	•
Hydraulic quick hitch	+	+	+	+	+	+
Adjustable tipping speed	•	•	•	•	•	•
Tilt cylinder protection	+	+	+	+	+	+
Loading buckets incl. a range of cutting tools	+	+	+	+	+	+
Light material bucket	+	+	+	+	+	+
Load holding valves	+	+	+	+	+	-
Float position	•	•	•	•	•	•
Pre-fitted for use with work cage	+	+	+	+	+	-
3rd electro-hydraulic, proportional control circuit, adjustable delivery flow	+	+	+	+	+	+
3rd electro-hydraulic control circuit for continuous sweeper and snow blower operation	+	+	+	+	+	+
4th electro-hydraulic, proportional control circuit, adjustable delivery flow	+	+	+	+	+	-
4th electro-hydraulic control circuit for continuous sweeper and snow blower operation	+	+	+	+	+	-



Operator's Cab

	550	556	566	576	580	586
Adaptive working lighting	+	+	+	+	+	+
Access assistance to facilitate cleaning windscreen	•	•	•	•	•	•
Exterior mirror, electrical adjustable, with heating	+	+	+	+	+	+
Exterior mirror, tiltable and adjustable	•	•	•	•	•	•
Operating hour meter (integrated in display unit)	•	•	•	•	•	•
Operating hour meter (mechanic)	+	+	+	+	+	+
Electronical theft protection with code	+	+	+	+	+	+
Electronical theft protection with/without driver identification	+	+	+	+	+	+
Storage box left	•	•	•	•	•	•
Operator seat "Comfort" – air sprung with seat heating	•	•	•	•	•	•
Operator seat "Premium" – active air-suspension with seat air-condition, seat heating and headrest	+	+	+	+	+	+
Particle filter F7	•	•	•	•	•	•
Fire extinguisher in cab 2 kg	+	+	+	+	+	+
Fire extinguisher in cab 6 kg	+	+	+	+	+	+
Audible horn control integrated into Liebherr control lever	+	+	+	+	+	+
Interior mirror right	•	•	•	•	•	•
Interior mirror left and right	+	+	+	+	+	+
Joystick steering	+	+	+	+	+	+
Floor mat	•	•	•	•	•	•
Clothes hooks (2 pieces)	•	•	•	•	•	•
Air conditioning system	•	•	•	•	•	•
Automatic air conditioning system	+	+	+	+	+	+
Cool box	+	+	+	+	+	+
3 way continuously adjustable steering column (height-adjustable, tilting, folding)	•	•	•	•	•	•
Steering stabilisation	•	•	•	•	•	•
LiDAT total use 1 year (for free)	•	•	•	•	•	•
Liebherr control lever with mini-joystick for 3rd and 4th electro-hydraulic proportional control circuit moving with operator's seat	+	+	+	+	+	+
Liebherr control lever moving with operator's seat (incl. kick down, travel direction)	•	•	•	•	•	•
Liebherr multi-lever control system moving with operator's seat (incl. kick down, travel direction)	+	+	+	+	+	+
Liebherr key (Remote Key)	+	+	+	+	+	+
Premiumdisplay (Touchscreen), with height adjustment and tilting function	•	•	•	•	•	•
Preparation for radio installation	+	+	+	+	+	+
Radio Liebherr "Comfort" (SD/USB/AUX/BLUETOOTH/handsfree set)	+	+	+	+	+	+
Radio Liebherr "Standard" (SD/USB/AUX)	+	+	+	+	+	+



Operator's Cab

	550	556	566	576	580	586
Amber beacon swiveling/fixed	+	+	+	+	+	+
Soundproof ROPS/FOPS cab	•	•	•	•	•	•
Bucket return with button integrated into Liebherr control lever	+	+	+	+	+	+
Wipe and wash system	•	•	•	•	•	•
Windscreen wiper single-sweep function with button integrated into the Liebherr control lever	+	+	+	+	+	+
Headlights rear, single design, halogen/LED	+	+	+	+	+	+
Headlights rear, double design, LED	+	+	+	+	+	+
Headlights front, double design, halogen	•	•	•	•	•	•
Headlights front, double design, LED	+	+	+	+	+	+
Sliding window left/right	•	•	•	•	•	•
Windscreen guard	+	+	+	+	+	+
Sunblind rear	+	+	+	+	+	+
Sunblind front	•	•	•	•	•	•
Power socket 12 V	•	•	•	•	•	•
First aid kit	+	+	+	+	+	+
Preparation for protective ventilation and dust filtrating device	+	+	+	+	+	+
Wide angle mirror	+	+	+	+	+	+
Cigarette lighter	•	•	•	•	•	•
2-in-1 steering – changeable	+	+	+	+	+	-



Safety

	550	556	566	576	580	586
Front space monitoring on operator's cab (with Liebherr camera via Liebherr display)	+	+	+	+	+	+
Country-specific versions	+	+	+	+	+	+
Emergency steering system	•	•	•	•	•	•
Reversing obstruction detector	+	+	+	+	+	+
Back-up alarm acoustic/visual	+	+	+	+	+	+
Rear space monitoring with camera (integrated in display unit)	•	•	•	•	•	•
Skyview 360°	+	+	+	+	+	+

• = Standard, + = Option, - = not available

The Liebherr Group of Companies



Wide Product Range

The Liebherr Group is one of the largest construction equipment manufacturers in the world. Liebherr's high-value products and services enjoy a high reputation in many other fields. The wide range includes domestic appliances, aerospace and transportation systems, machine tools and maritime cranes.

Exceptional Customer Benefit

Every product line provides a complete range of models in many different versions. With both their technical excellence and acknowledged quality, Liebherr products offer a maximum of customer benefits in practical applications.

State-of-the-art Technology

To provide consistent, top quality products, Liebherr attaches great importance to each product area, its components and core technologies. Important modules and components are developed and manufactured in-house, for instance the entire drive and control technology for construction equipment.

Worldwide and Independent

Hans Liebherr founded the Liebherr family company in 1949. Since that time, the enterprise has steadily grown to a group of more than 130 companies with over 41,000 employees located on all continents. The corporate headquarters of the Group is Liebherr-International AG in Bulle, Switzerland. The Liebherr family is the sole owner of the company.

www.liebherr.com

Liebherr-Werk Bischofshofen GmbH

Postfach 49, A-5500 Bischofshofen

+43 50809 1-0, Fax +43 50809 11385

www.liebherr.com, E-Mail: info.lbh@liebherr.com

www.facebook.com/LiebherrConstruction